

CATALOGUE TECHNIQUE FRAPPE 500

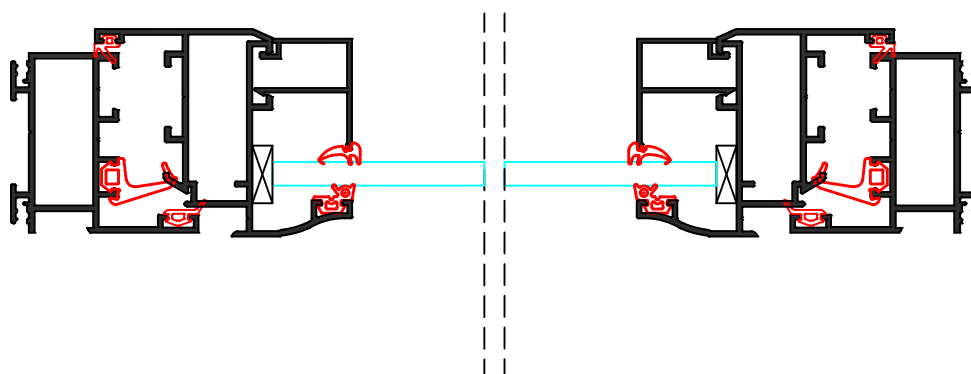

» DESCRIPTIF.....	page: 02
» LES POSSIBILITES DE LA GAMME.....	page: 03
» PROFILS ET ACCESSOIRES.....	page: 04-11
» PARCLOSES ET JOINTS.....	page: 12
» LES SYSTEMES DE FERMETURE.....	page: 13-14
» USINAGE DES CREMONES.....	page: 15
» DEBIT DE LA TIGE 503 POUR CREMONE 2 FOURCHES 557F.....	page: 16
» DEBIT DE LA TIGE 503 POUR CREMONE 2 FOURCHES 556F.....	page: 17-18
» POSE DU DORMANT.....	page: 19
» ASSEMBLAGE DU DORMANT POUR O.F.1 VANTAIL.....	page: 20-21
» ASSEMBLAGE DE L'OUVRANT POUR O.F.1 VANTAIL.....	page: 22
» OUVRANT A LA FRANCAISE 1 VANTAIL.....	page: 23
» DETAILS DES FERRURES POUR OSCILO-BATTANTS.....	page: 24-25
» MONTAGE DU VITRAGE AVEC PARCLOSE.....	page: 26
» LIAISON DORMANT ET TRAVERSE.....	page: 27
» ASSEMBLAGE DES TRAVERSES PAR VIS	page: 28
» MONTAGE DU CAVALIER REF 562-563.....	page: 29
» MONTAGE DU BAS DE PORTE.....	page: 30
» SERRURE 1 POINT REF 560.....	page: 31-33
» DEBITS ET COUPES.....	page: 34-68
» OUTILS ET DETAILS.....	page: 69-75

FENETRE ET PORTE A FRAPPE ALUKA SERIE 500**Concept du produit :**

Profilés en aluminium permettant la fabrication des châssis à frappe :

- Fenêtre à la française 1 vantail
- Fenêtre à la française double battante.
- Porte à la française 1 vantail.
- Porte à la française double battante.
- Fixe.
- Soufflet.
- Oscillo-battant.
- Châssis composé.

Dormants :

- Tubulaire d'une base de 45 mm avec la possibilité de clipper une bavette de 36,6 mm. et des couvre-joints de 31,6 ou 44 mm.

Ouvrants :

- Tubulaire de forme droite sur l'extérieur et arrondie sur l'intérieur. Leur largeur est de 52 mm.

Assemblage :

- Assemblage en coupe d'onglet, les dormants et les ouvrants au moyen d'équerres à pions.
- Toutes les pièces d'assemblage sont en aluminium.
- Les coupes sont étanchées avec un produit de type « Sikaflex ».

Remplissage:

- De 6 à 32 mm, maintenu par 2 joints en EPDM et une par close clippée d'une hauteur de 20 mm. (fond de feuillure).

Etanchéité

- L'étanchéité se fait par compression de 2 joints en EPDM lors de la fermeture, les 2 joints de battue tournants; Le joint froid central est positionné sur le dormant.

Ferrage :

- Paumelles aluminium, axe inox, contre plaque de fixation inox, interchangeables sans démontage de l'ouvrant.
- Paumelles renforcées par de la fibre de verre pour les fenêtres et portes-fenêtres.
- Elles sont réversibles et se posent après assemblage des cadres, sur l'ouvrant et le dormant par contre cale permettant le réglage en hauteur.

Verrouillage :

- Kit crémone fermeture haute et basse pour OF 1 ou 2 vantaux.
- Crémone à tourner réversible, le même pour les OF et les Oscillo-battants.
- Loqueteau pour vasistas sans usinage.
- Serrure multipoints pour les portes.

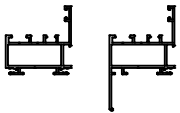
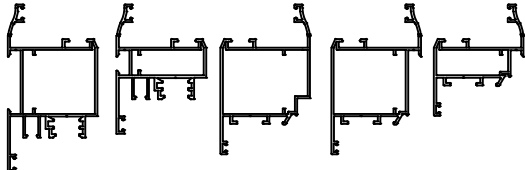
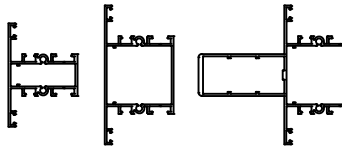
LES DORMANTS	LES OUVRANTS	LES TRAVERSES
		

CHASSIS A FRAPPE ET OSCILLO-BATTANTS

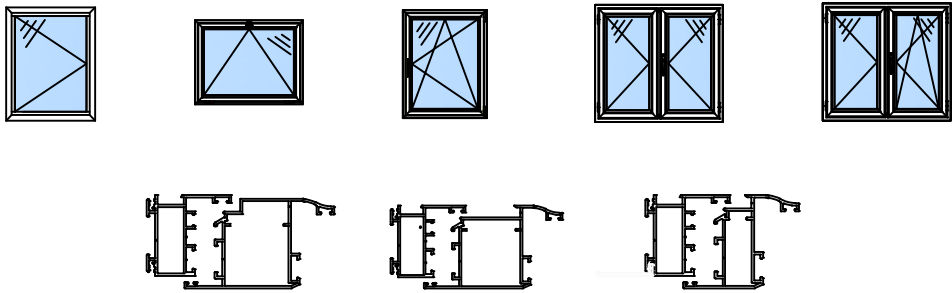

LES PORTES

LES CHASSIS COMPOSES

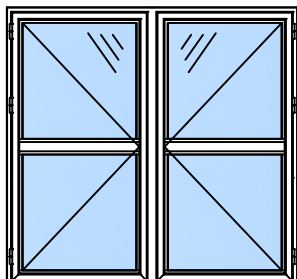
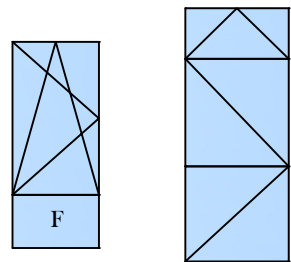
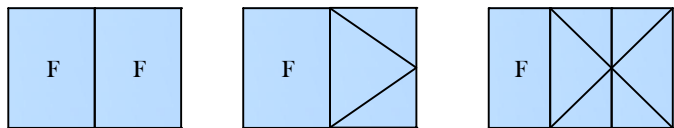
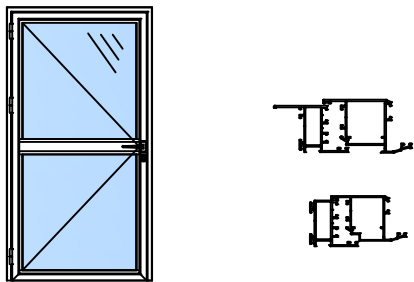

PROFILES ET ACCESSOIRES

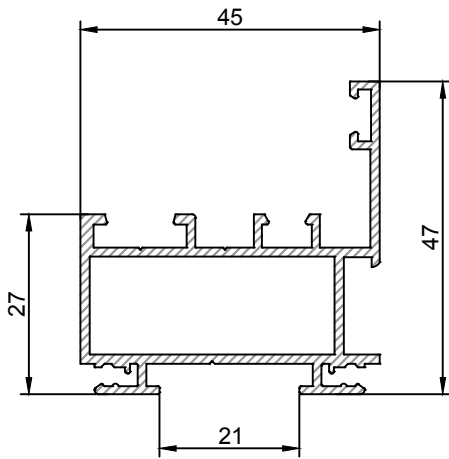

500

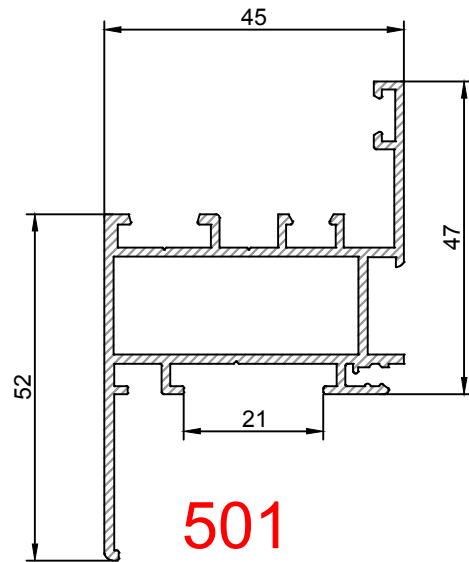

501

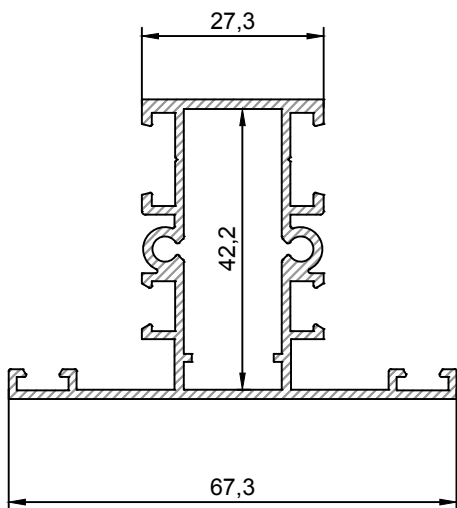

505

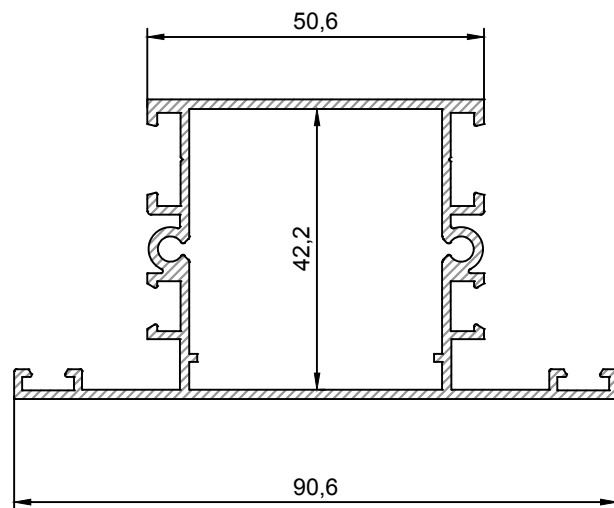

506

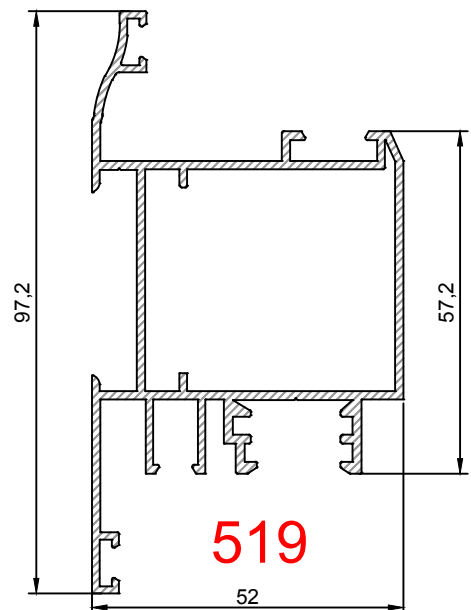
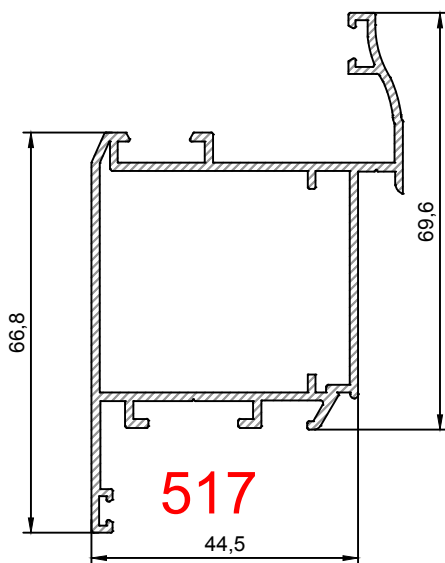
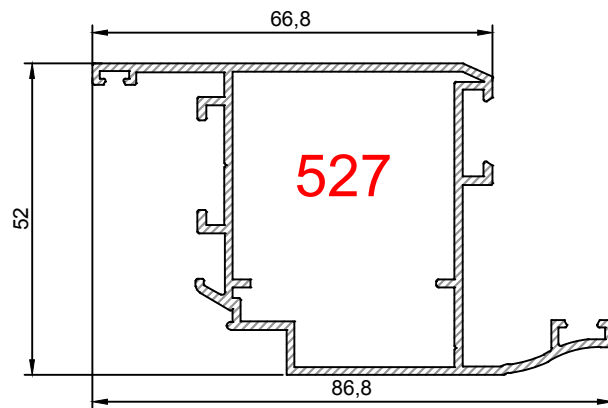
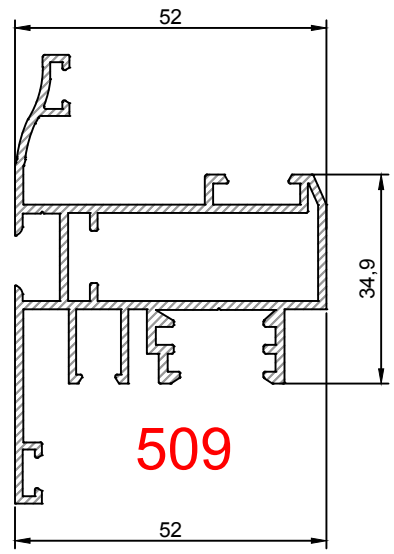
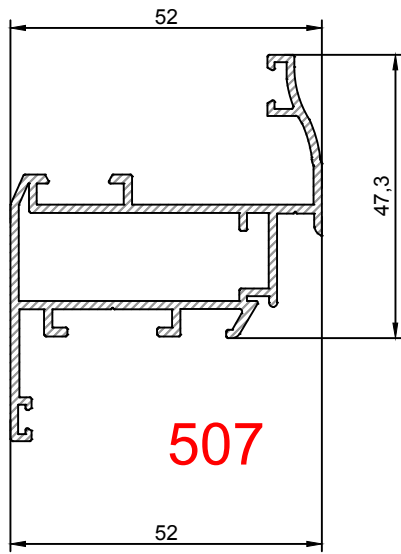

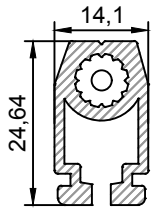

502

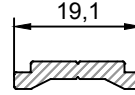

503

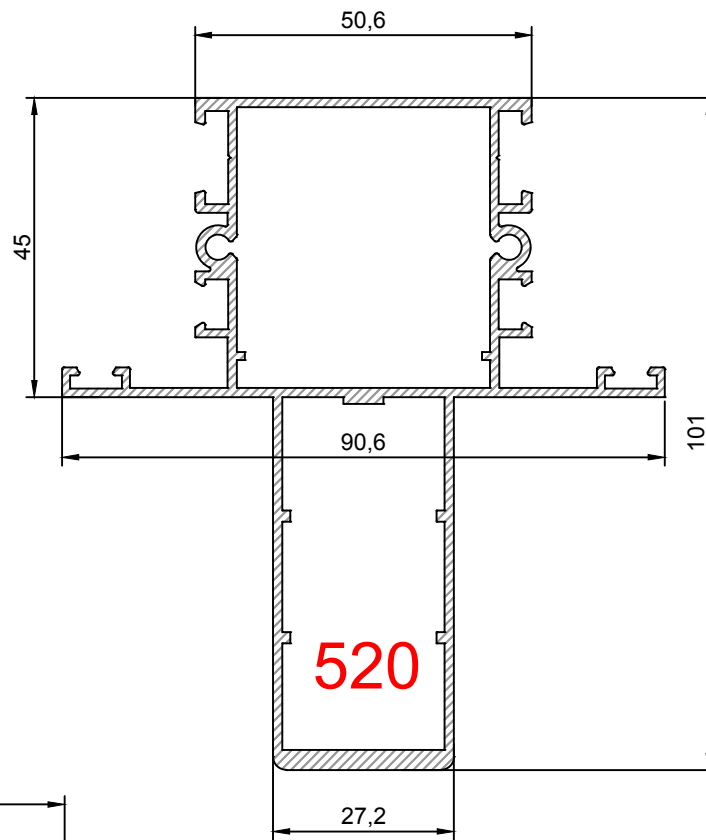

520

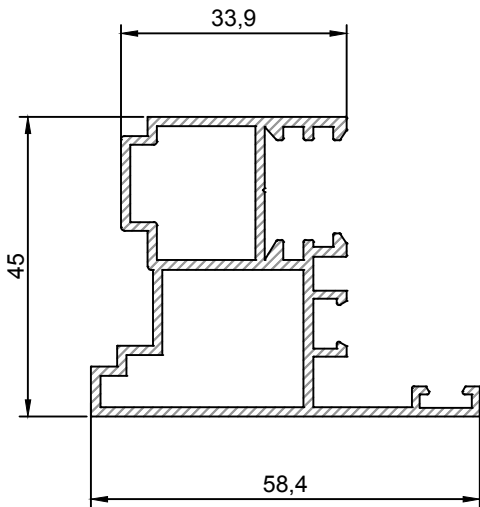

504

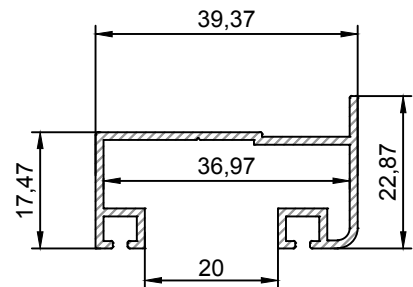

516

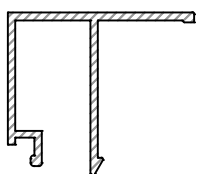

530

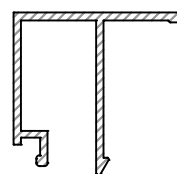

531

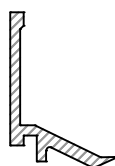



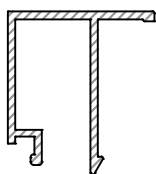

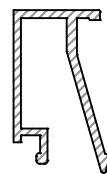

534



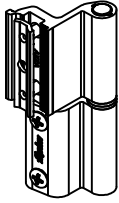
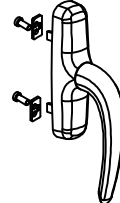
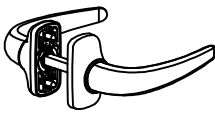
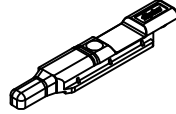
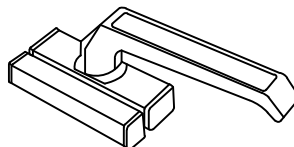
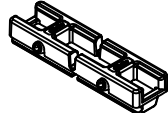

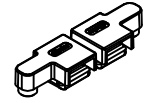

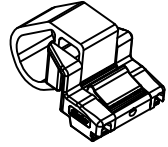
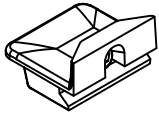

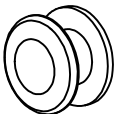
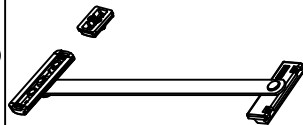
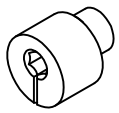
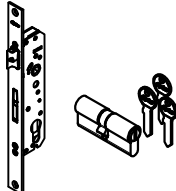

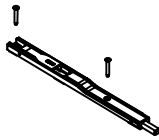
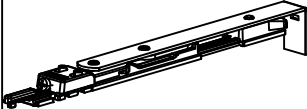
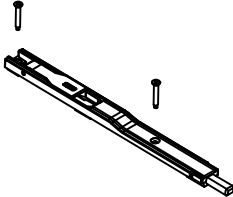
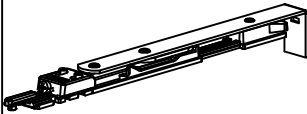
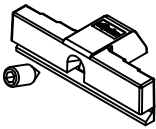
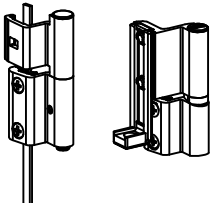

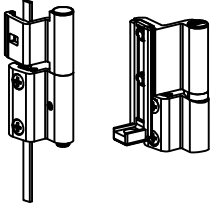

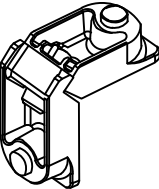
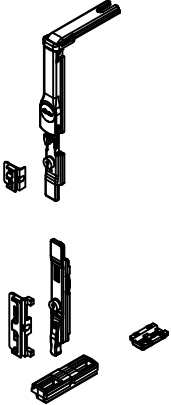
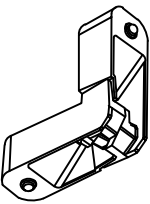

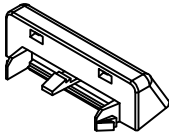

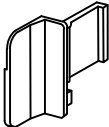
532

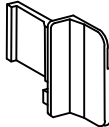

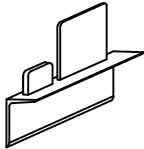
533

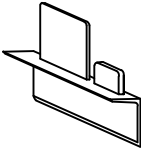
REF	ARTICLE	DESIGNATION	REF	ARTICLE	DESIGNATION
553F		PAUMELLE FRAPPE	557F		CREMONE 2 FOURCHES
554F		POIGNEE BEQUILLE HORUS MIDI	557/ET		EMBOU'T TRINGLE H. & B., 1 V. & 2 Vs.
555F		POIGNEE ANGLAISE PIENZA	557/G		GACHE H. & B., 1 V. & 2 Vs.
556F		CREMONE 1 FOURCHE & O/B	557/PA		PAIR D'ENTRAINEUR CREMONE 2 FOURCHES
556/EL		ENTRAINEUR 1 FOURCHE & O/B	558F		LOQUETEAU POUR SOUFFLET
556/GUI		GACHE UNIVERSEL INDUSTRIEL	559F/150		COMPAS POUR SOUFFLET 150 MM.
556/AR		AXE ENTRAINEUR POUR CREMONE 1 FOURCHE & O/B	559F/220		COMPAS POUR SOUFFLET 220MM.
556/SUP		AXE DE FERMETURE SUPPLEMENTAIRE	560		SERRURE 1 POINT COMPLET

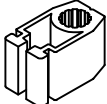
REF	ARTICLE	DESIGNATION	REF	ARTICLE	DESIGNATION
561F/220		VERROU TITAN 2 SEMI FIXE 220 MM.	565F		COMPAS OB DE 700
561F/450		VERROU TITAN 2 SEMI FIXE 450MM	565G		COMPAS OB DE 1200
561/GZ		GACHE EN ZAMAC	567F		PAUMELLE OB
561/GI		GACHE INFERIEUR ATLAS TITAN	567G		PAUMELLE OB
568F/GL		KIT O/B DE BASE GALICUBE	554F		CREMONE O/B
E-36-14		EQURE A VISSER DORMANT OUVRANT P.M	568F		KIT OSCILOBATTANT DE BASE
E-33.5-36		EQURE A VISSER OUVRANT PORTE FENETRE			
D12		BOUCHON D12	569		BUSETTE

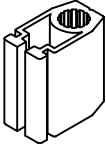
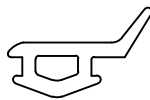
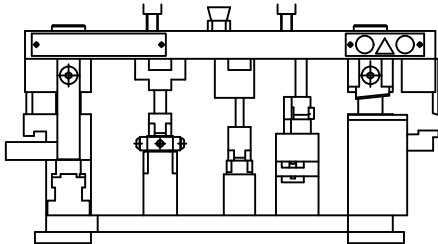
REF	ARTICLE		REF	ARTICLE	
570		ETANCHEITE INTERIEUR DROITE FRAPPE	591		JOINT FROID CENTRALE
571		ETANCHEITE INTERIEUR GAUCHE FRAPPE	592		JOINT BATTUE
572		ETANCHEITE EXTERIEUR DROITE FRAPPE	593		JOINT FEUILLURE
573		ETANCHEITE EXTERIEUR GAUCHE FRAPPE	594		JOINT DE VITRAGE 3MM
562		CAVALIER POUR TRAVERSE DE 70	595		JOINT DE VITRAGE 4MM
563		CAVALIER POUR TRAVERSE DE 90	596		JOINT DORMANT
			B2/B3	2 PORTE-MATRICES FRAPPE 	

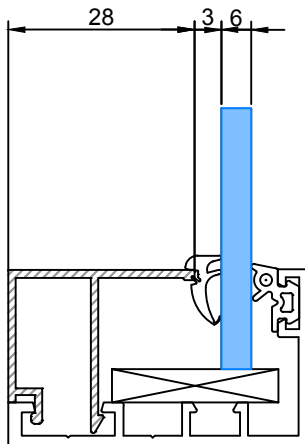

530

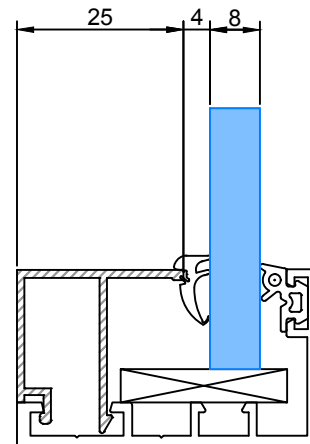

531

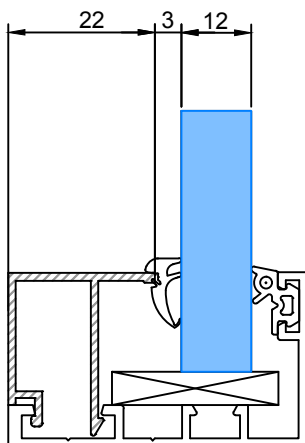

532

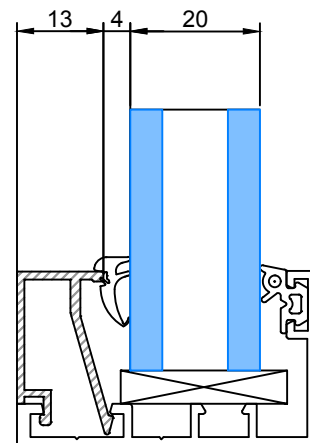

533

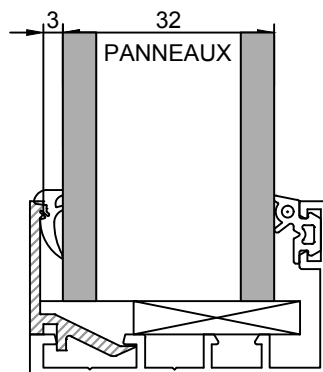

534

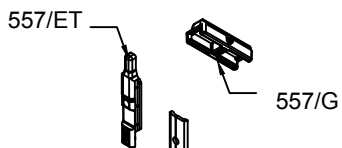

**KIT avec crémonne à 2
FOURCHES**

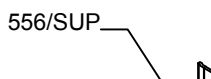
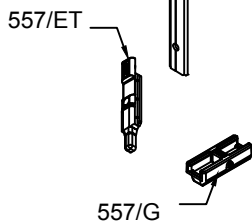
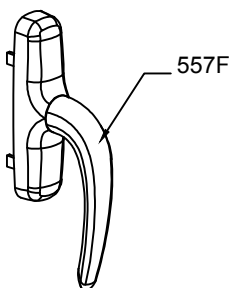
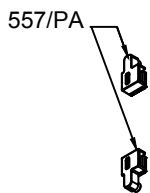

**Crémone 1 FOURCHE
entraîneur à RIVER**

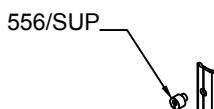
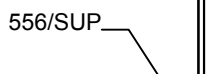
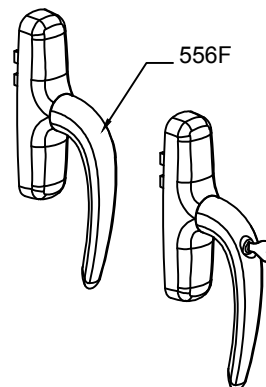
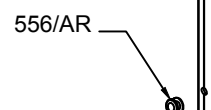

**Crémone 1 FOURCHE
entraîneur MOULE**

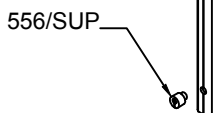
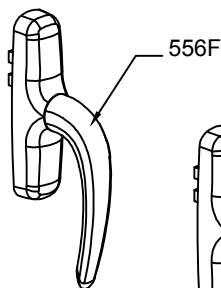
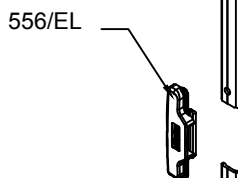

Pour les châssis inférieurs à 950 x 1900, les deux solutions sont possibles

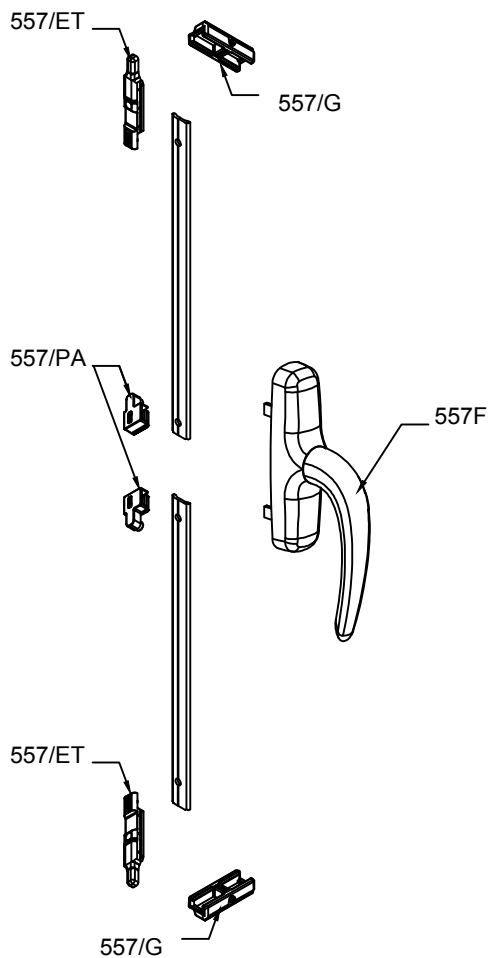

Système pour ouvrant à la
française
950 x 1900 Max.

**A UTILISER DANS LES CAS
SUIVANTS:**

- Ouvrant à la française.
- Oscilo-battant.
- Pour avoir une crémone à clef.

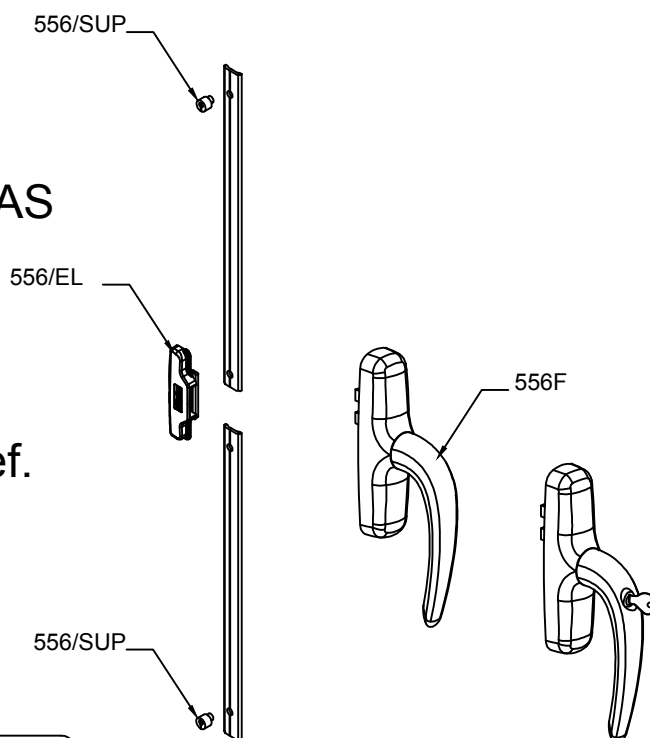

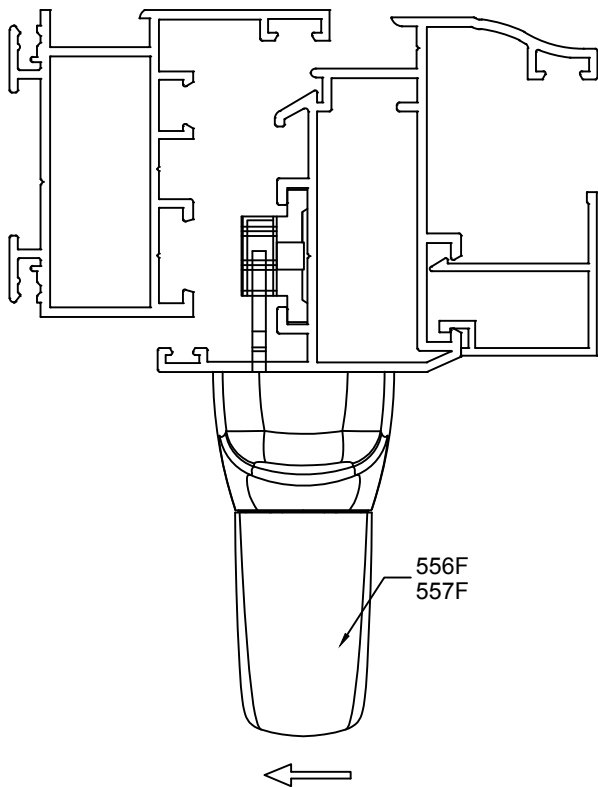

Pousser au maximum la cremone vers la battue

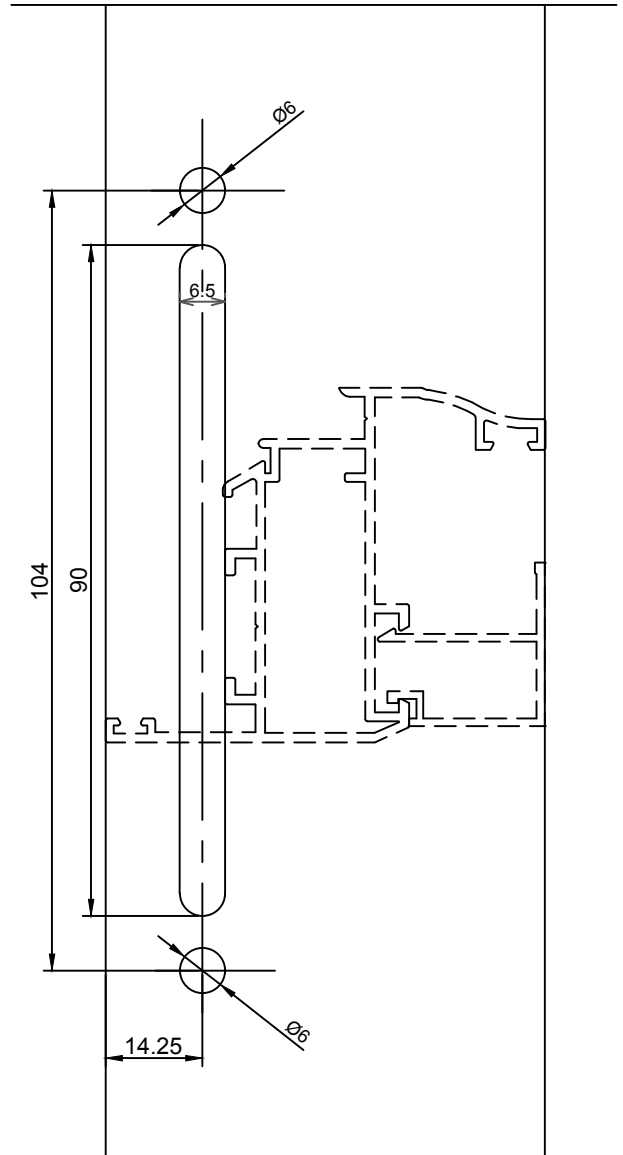

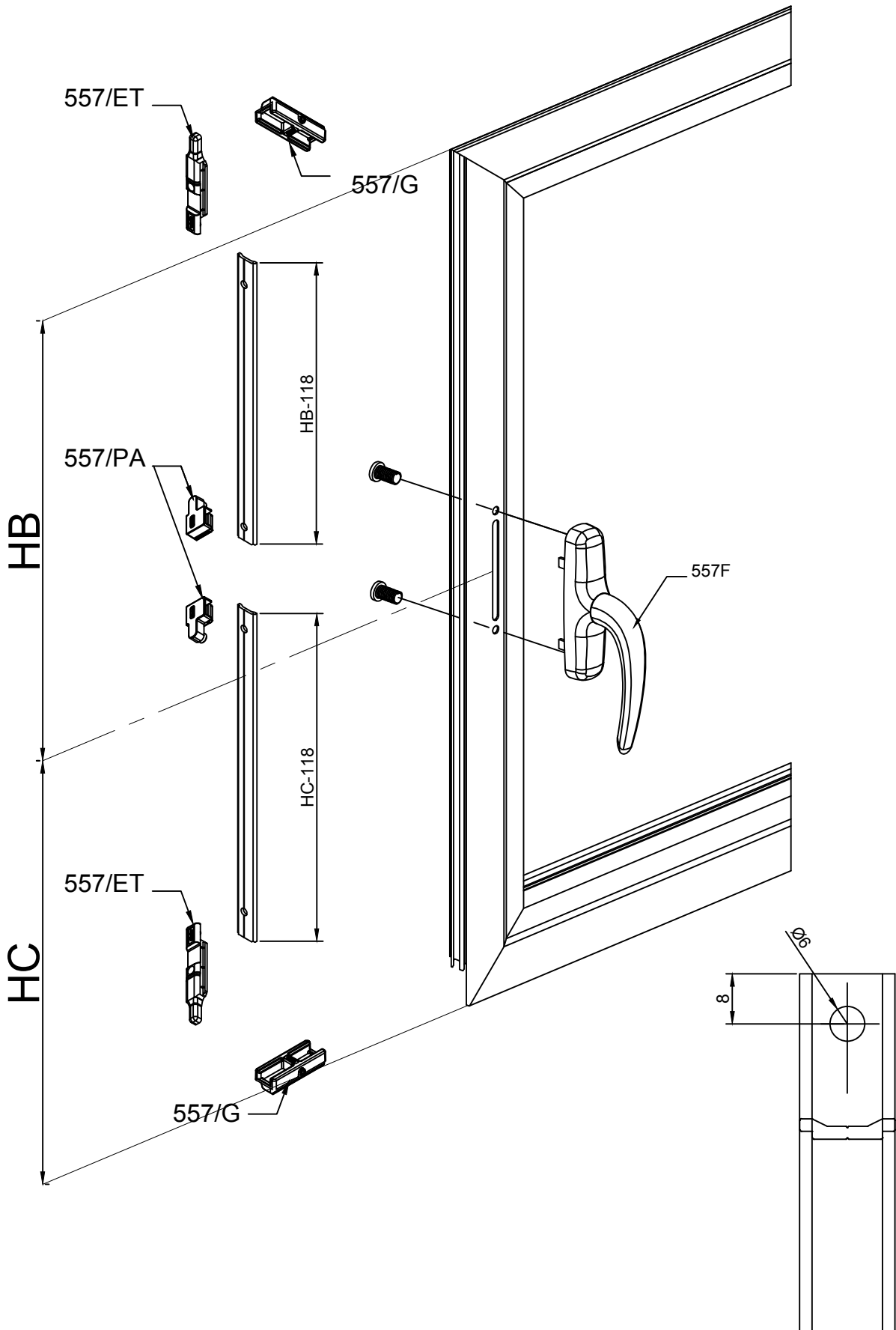

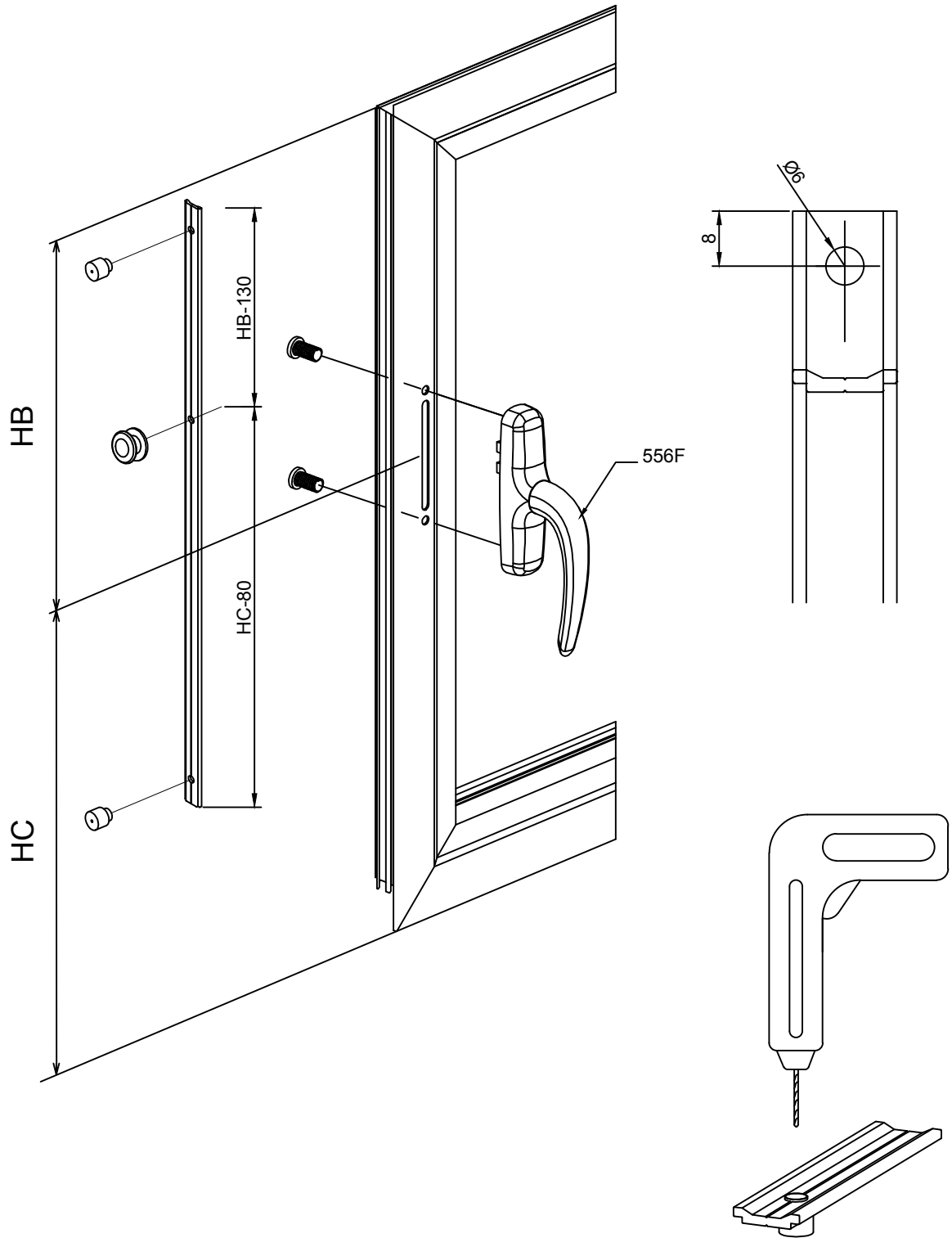

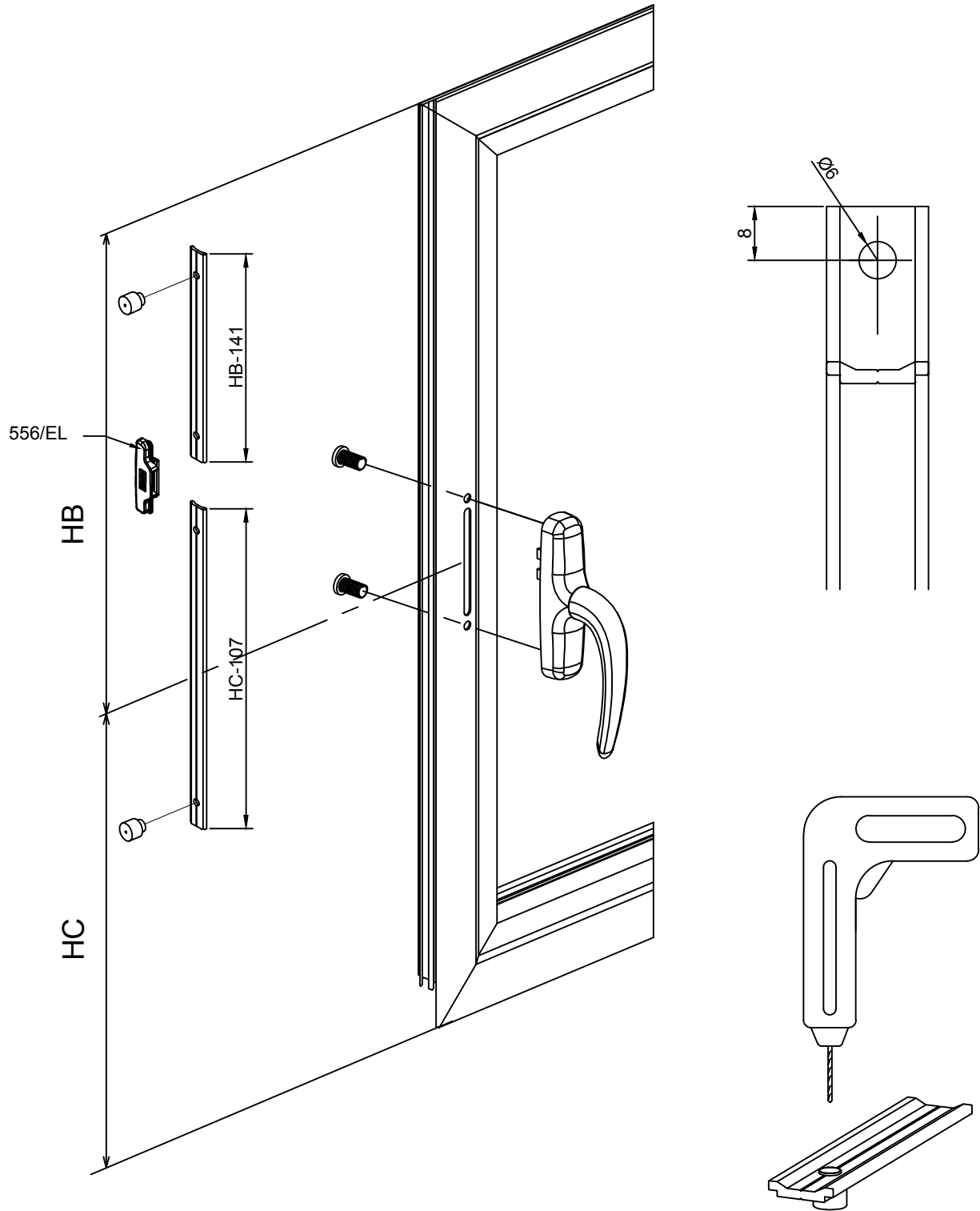

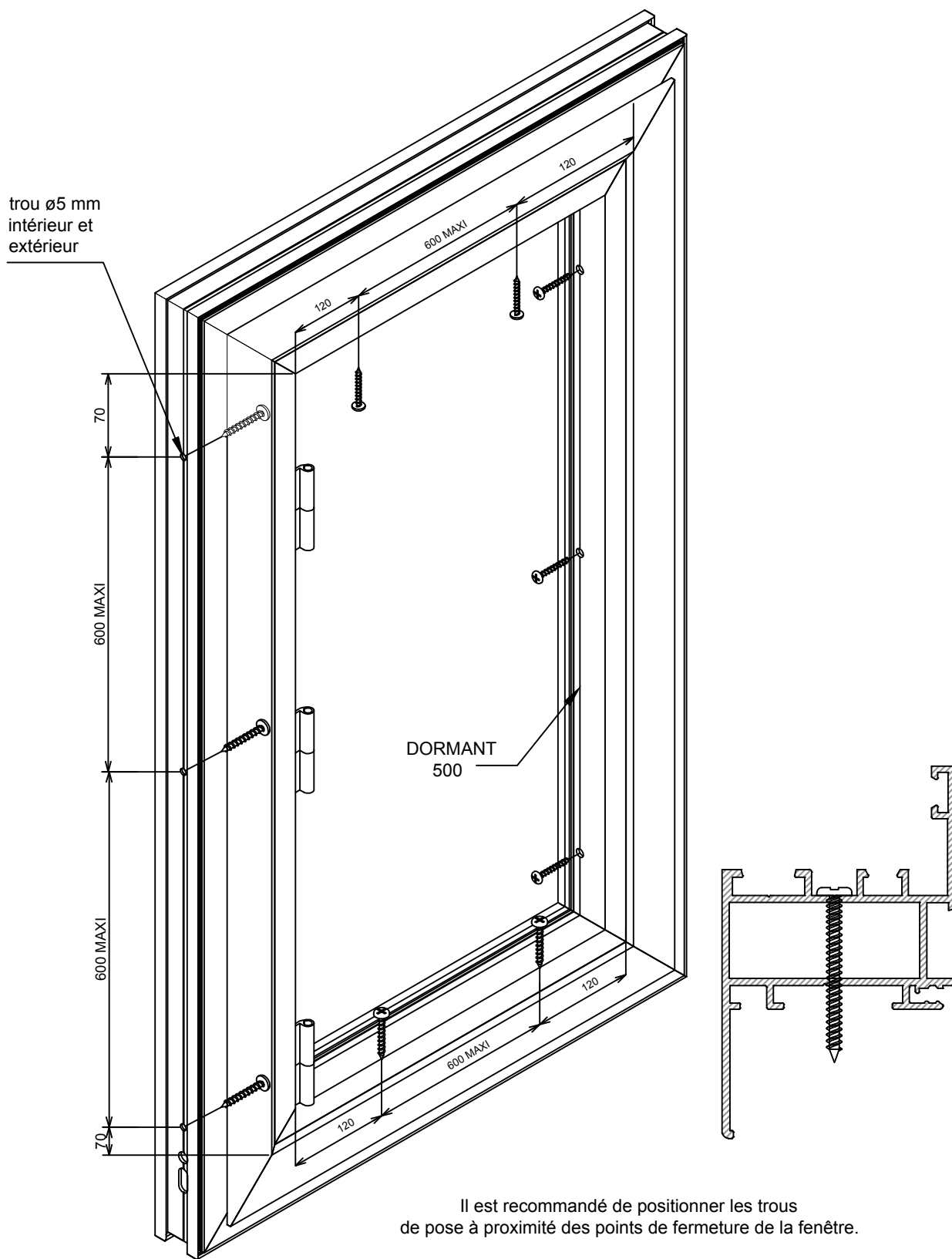

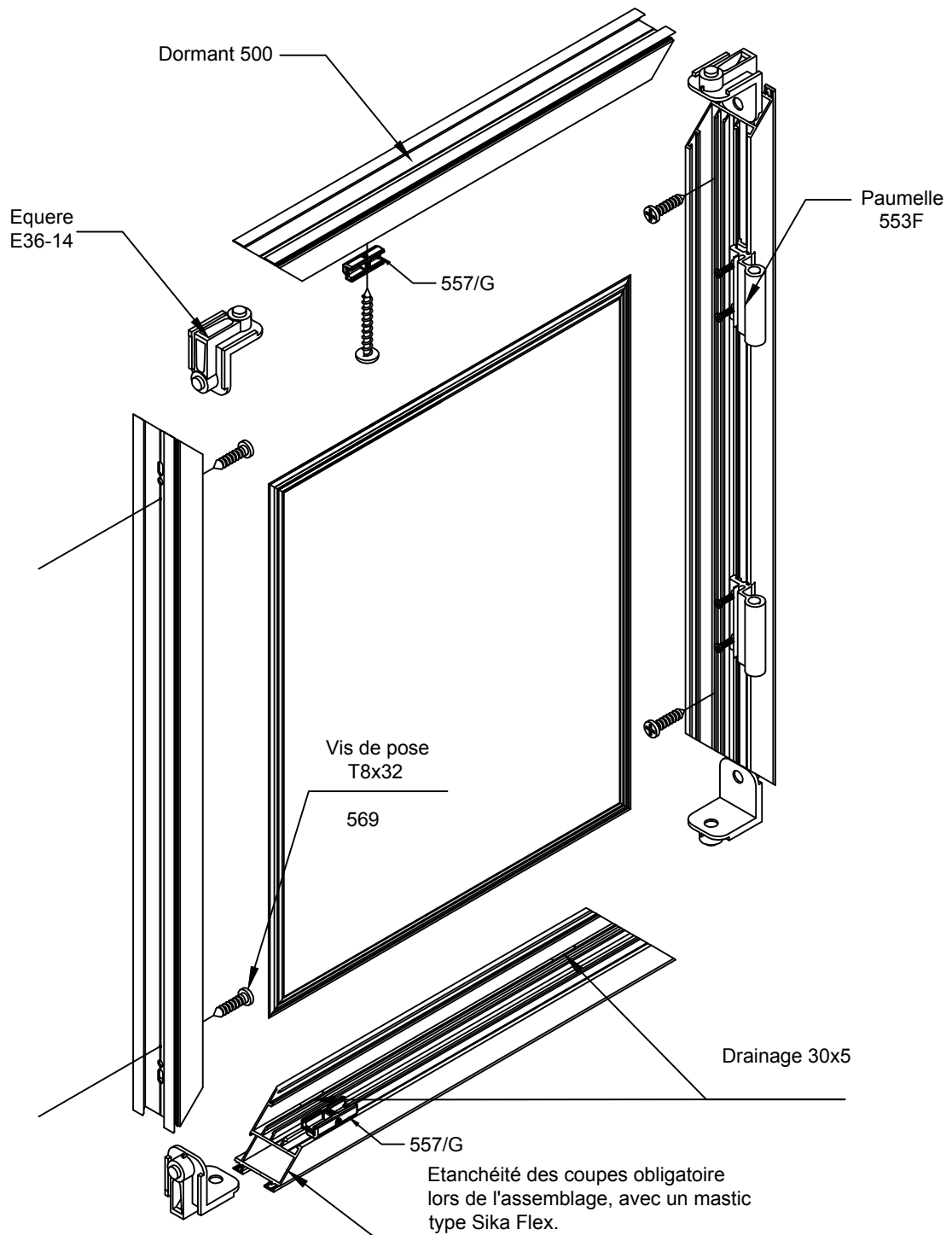

DETAILS D'ASSEMBLAGE

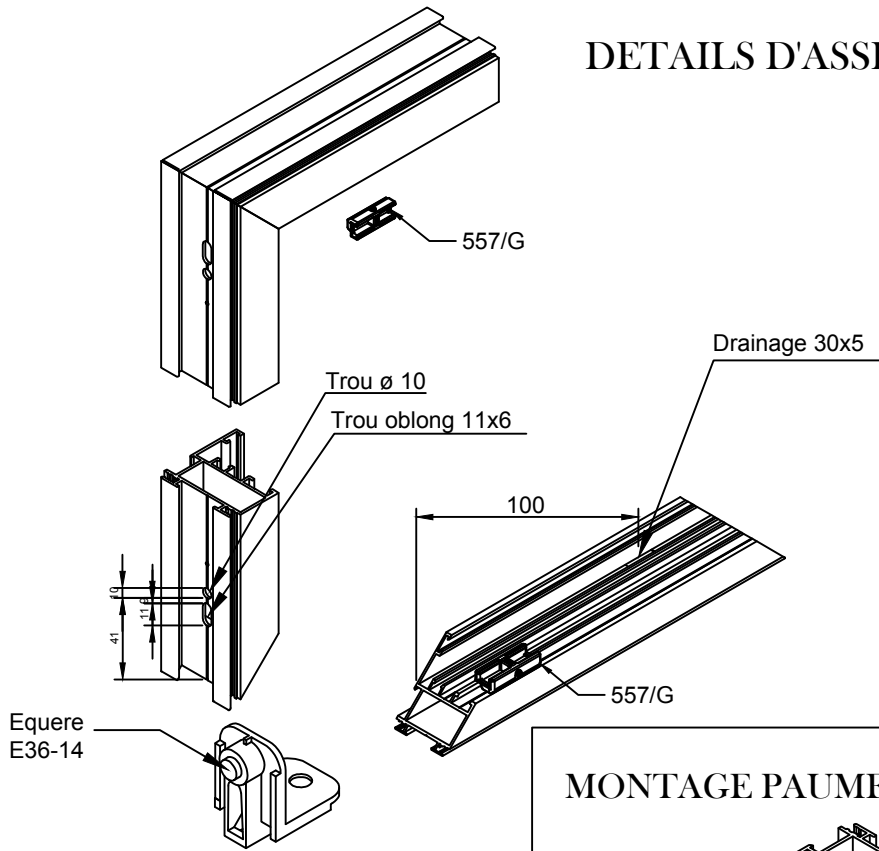

MONTAGE PAUMELLE Réf.553F

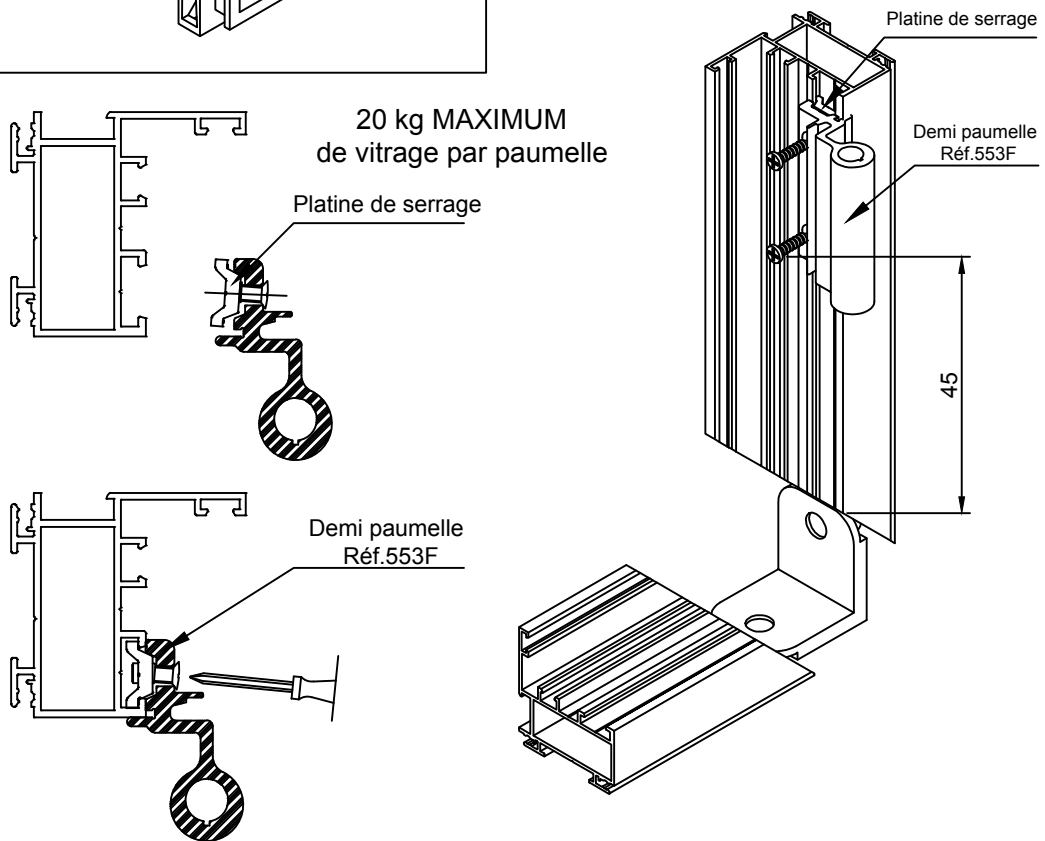

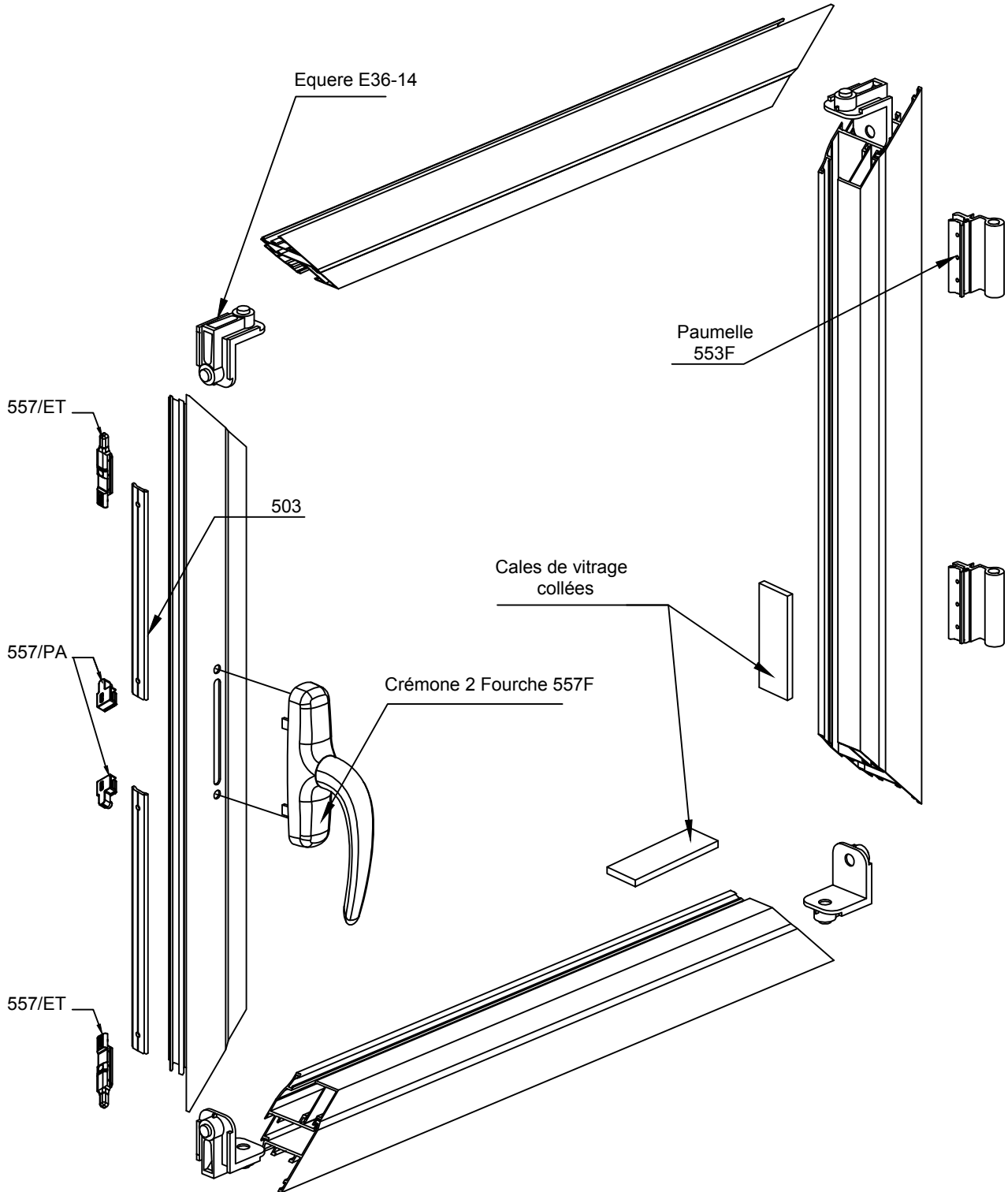

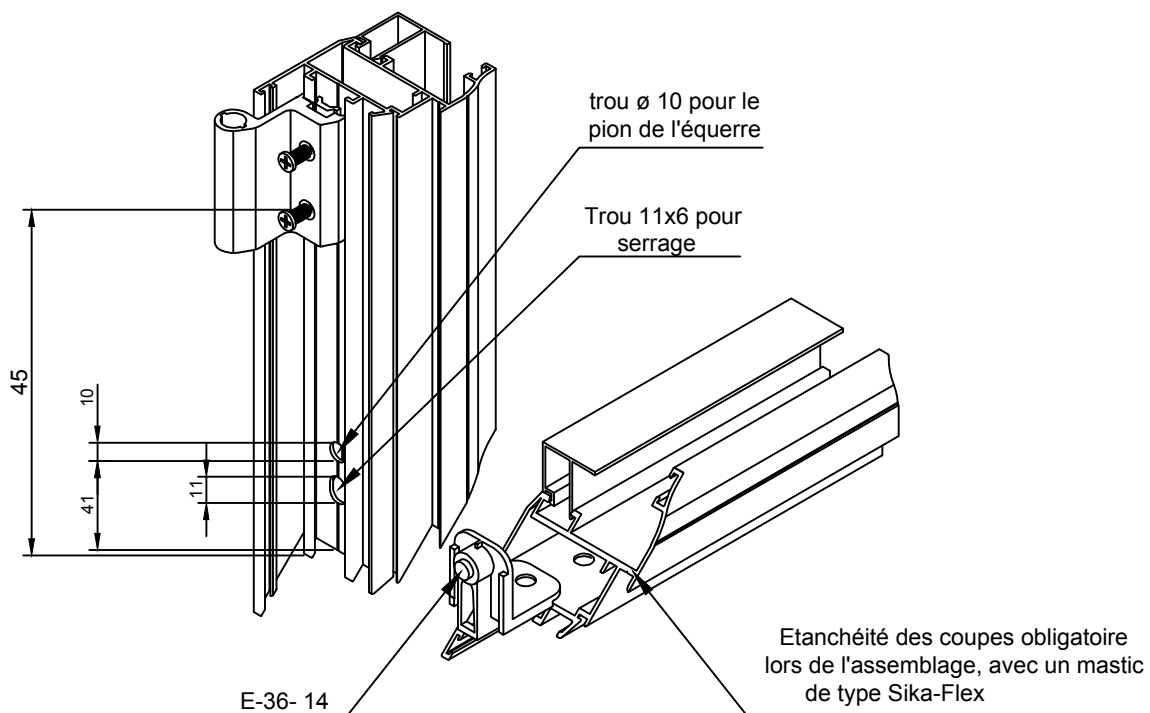

N.B: une fois la paumelle vissée,
l'egrot doit être positionné derrière

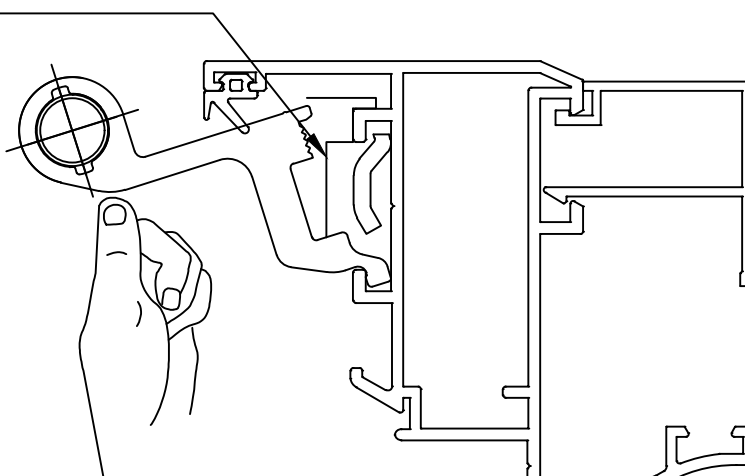

POUSSER LA PAUMELLE
POUR COMPRIMER LE
JOINT DE BATTEMENT

POSITION PAUMELLE

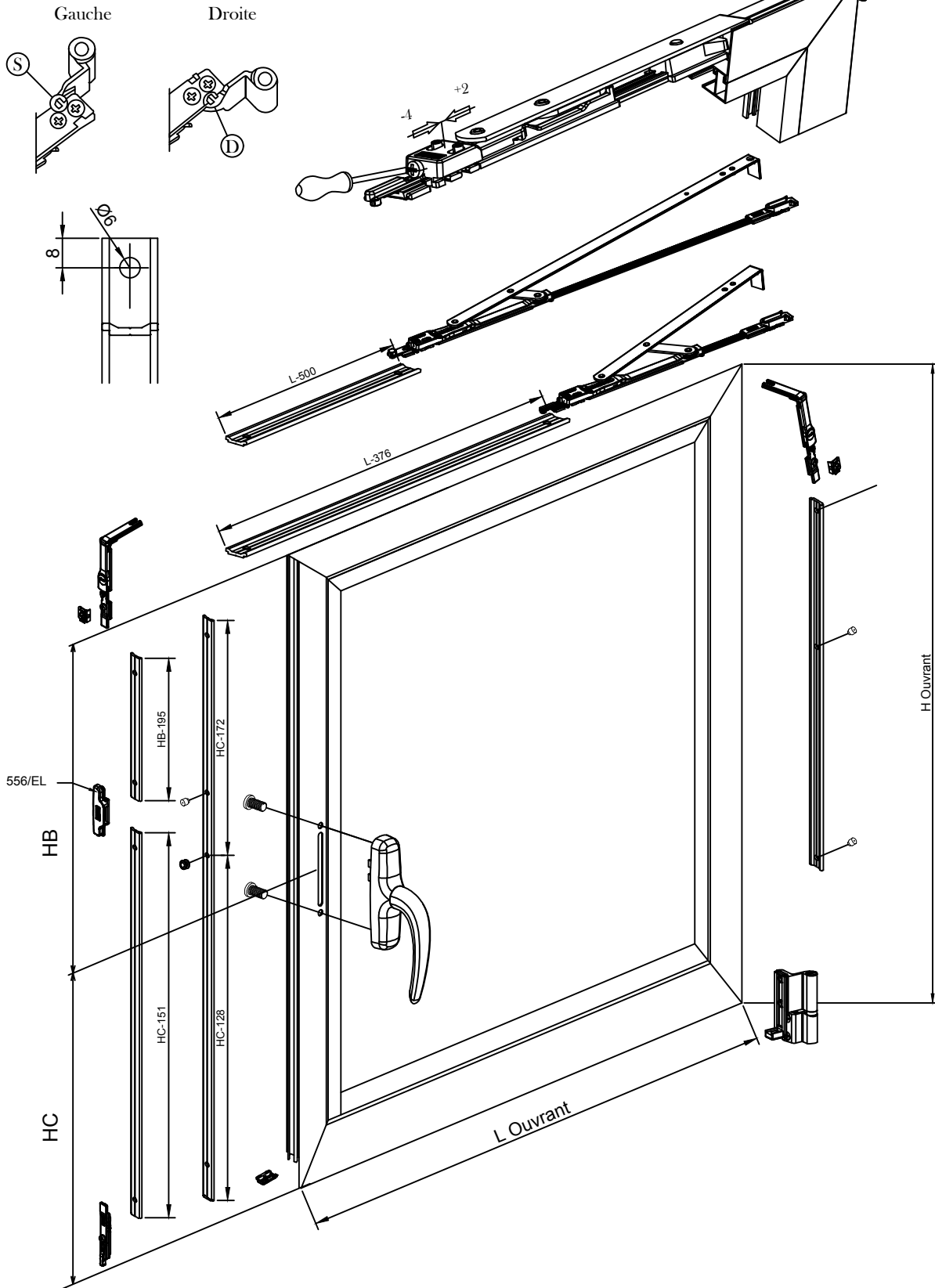

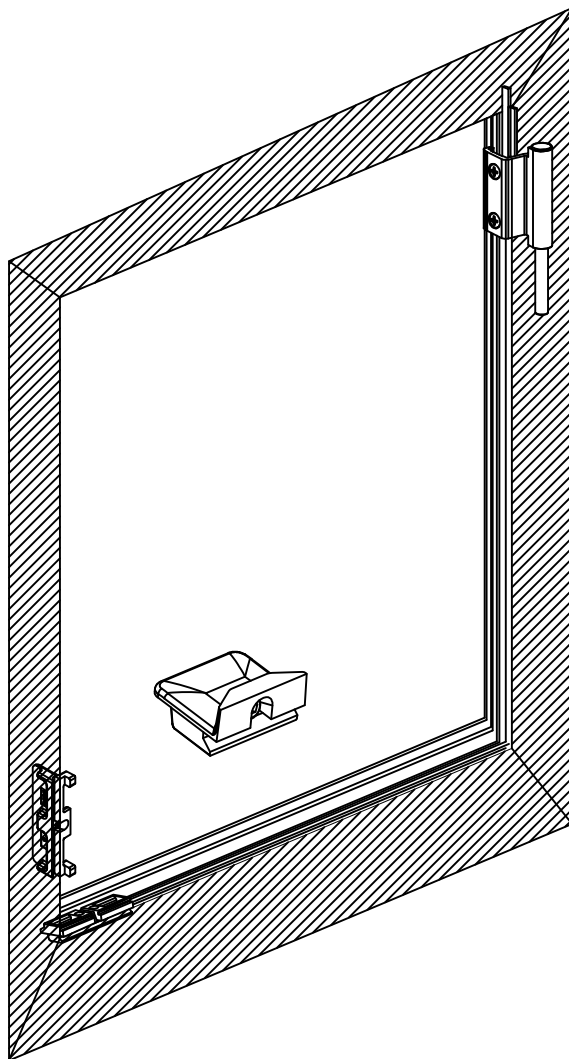
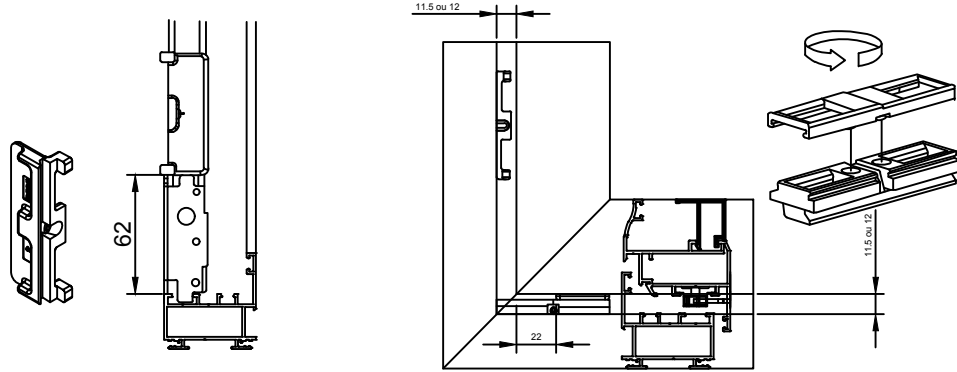

REGLAGE DE LA
PAUMELLE

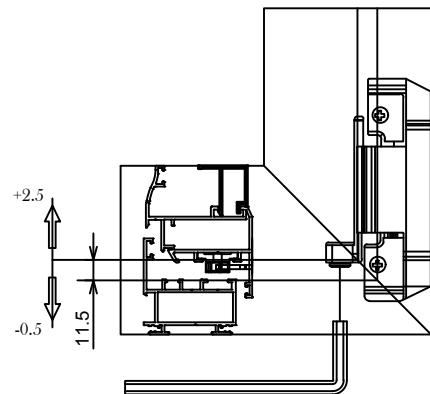

REGLAGE DU POINT
DE FERMETURE

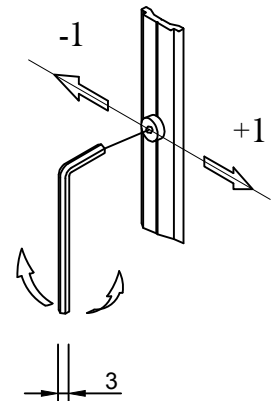

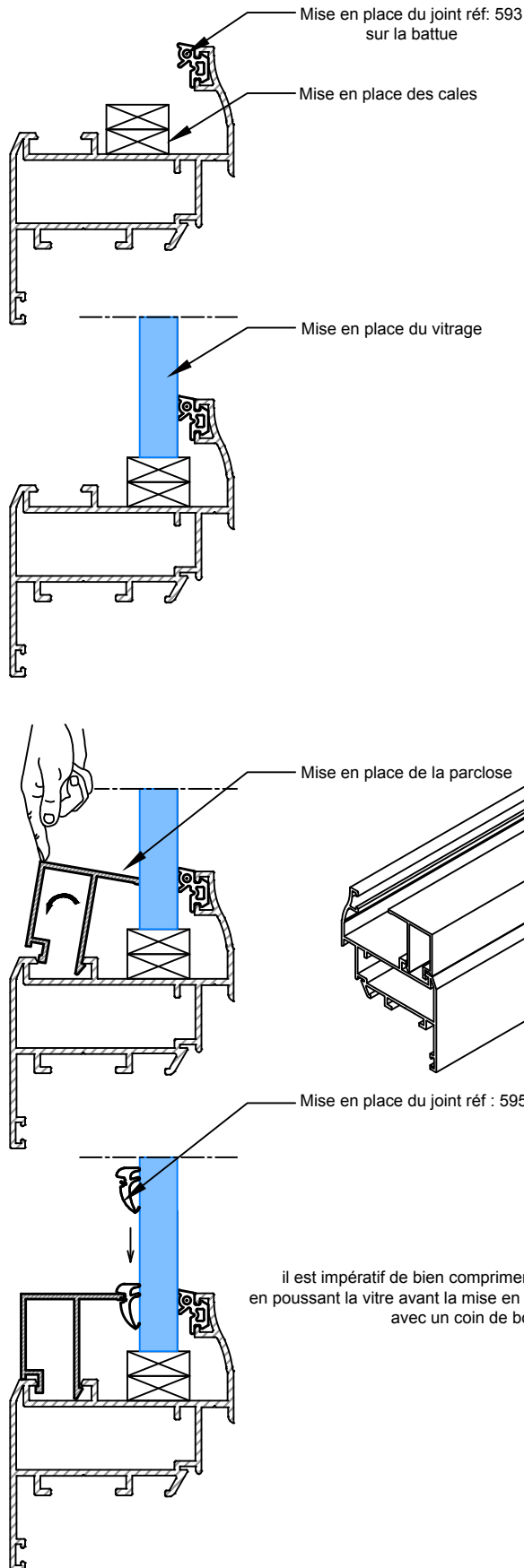

POSITIONNEMENT DES CALES SUIVANT LES TYPES DE CHASSIS

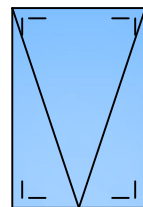
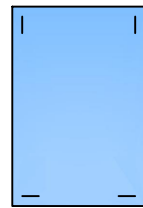
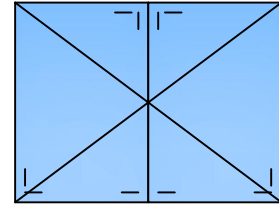

il est impératif de bien comprimer le joint extérieur en poussant la vitre avant la mise en place du joint réf: 595 avec un coin de bois

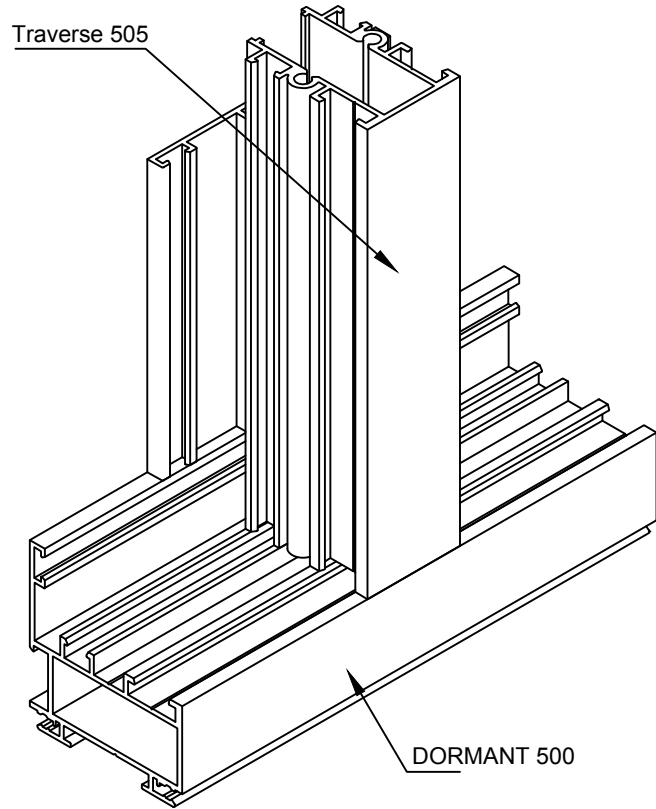
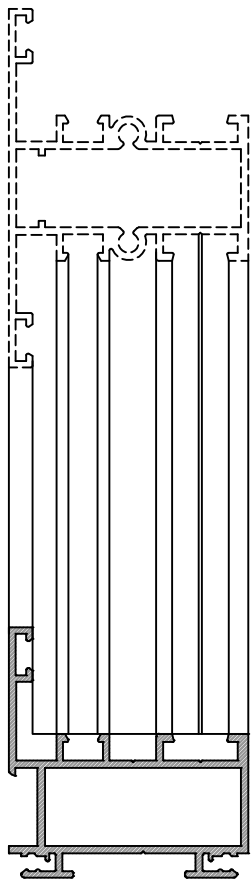

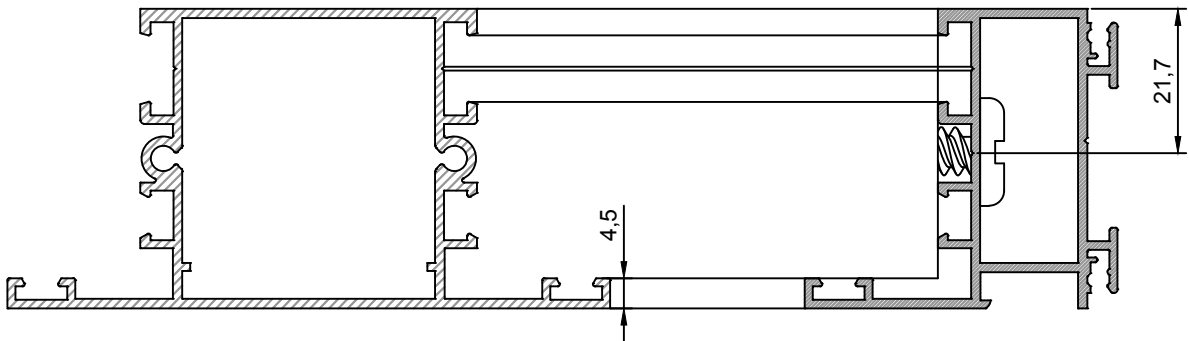
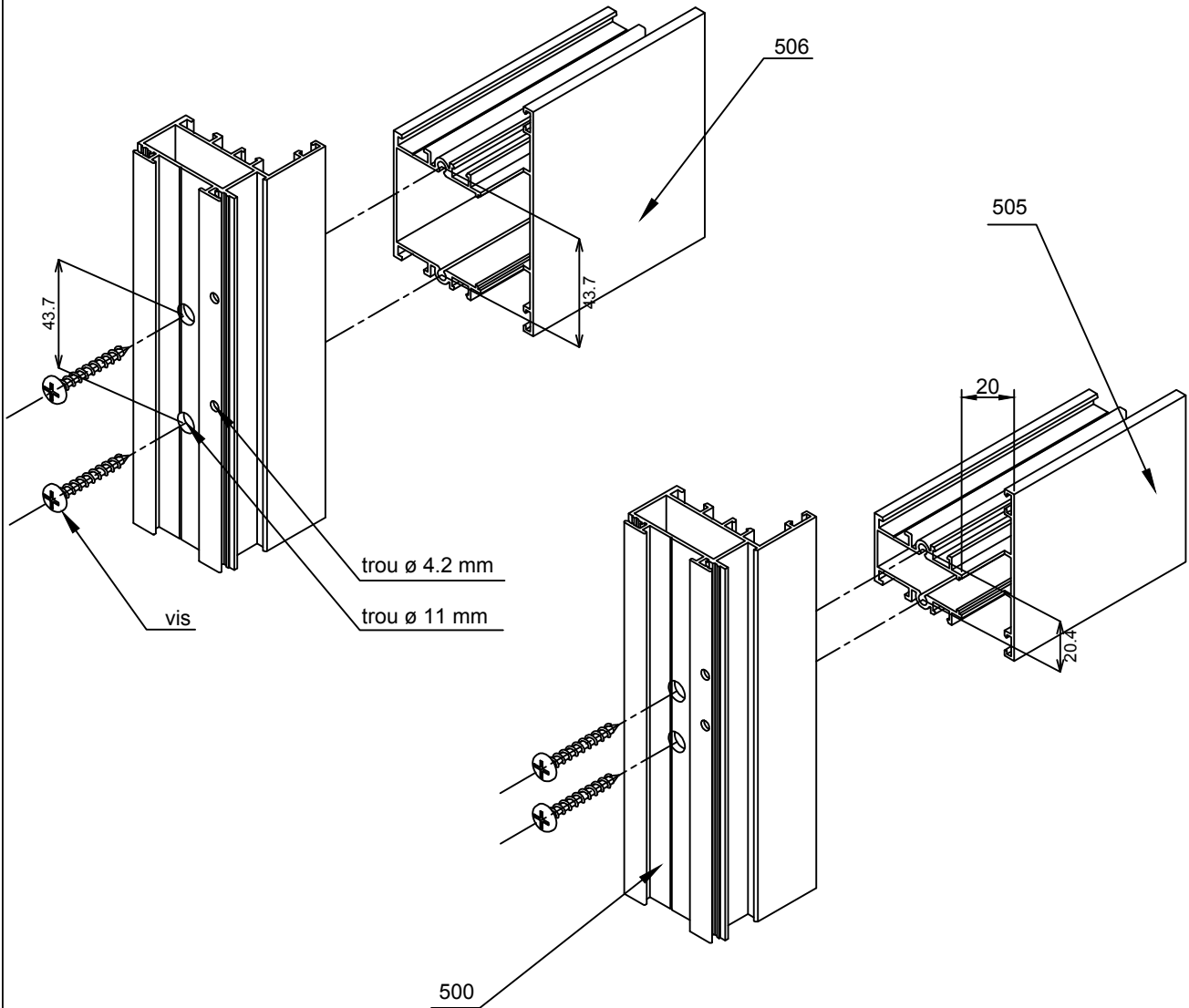

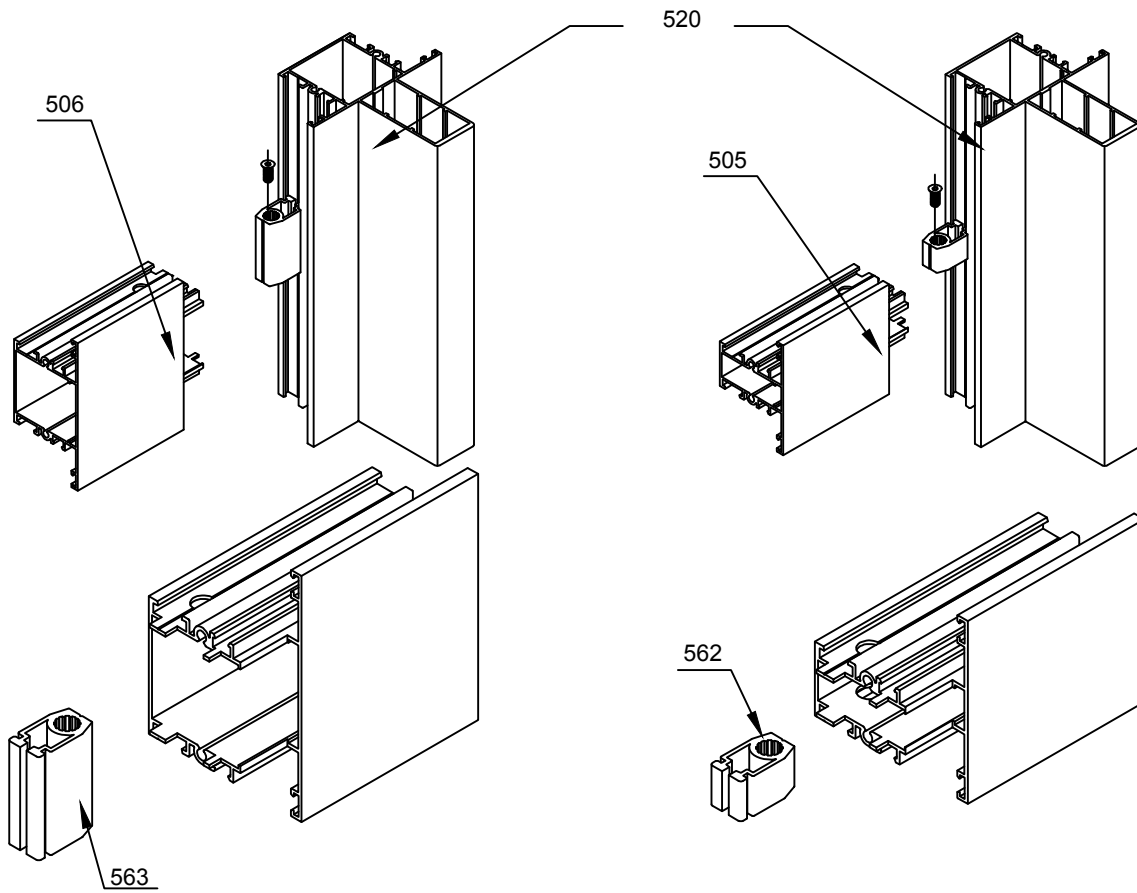

Pour une bonne tenue de la traverse,
l'usinage doit être ajusté et en contact
avec le battement

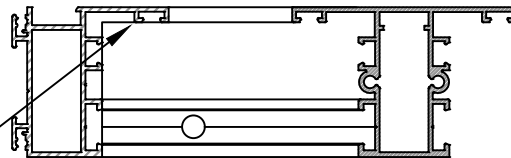

MONTAGE DES CAVALIERS REF : 562-563

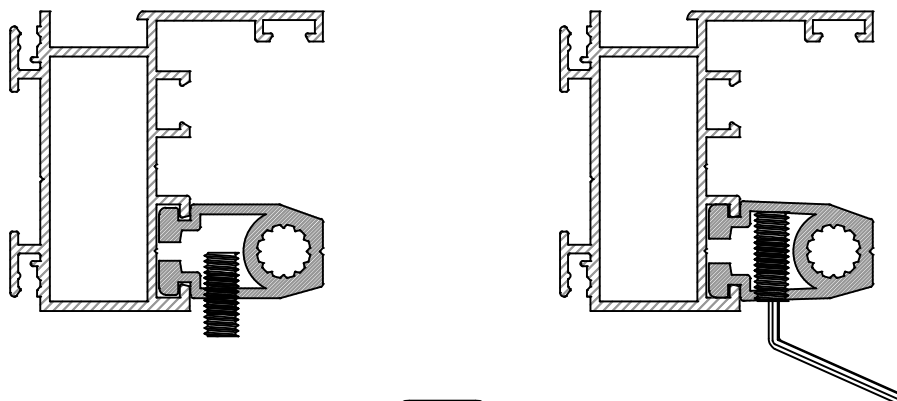

MONTAGE DU BAS DE PORTE

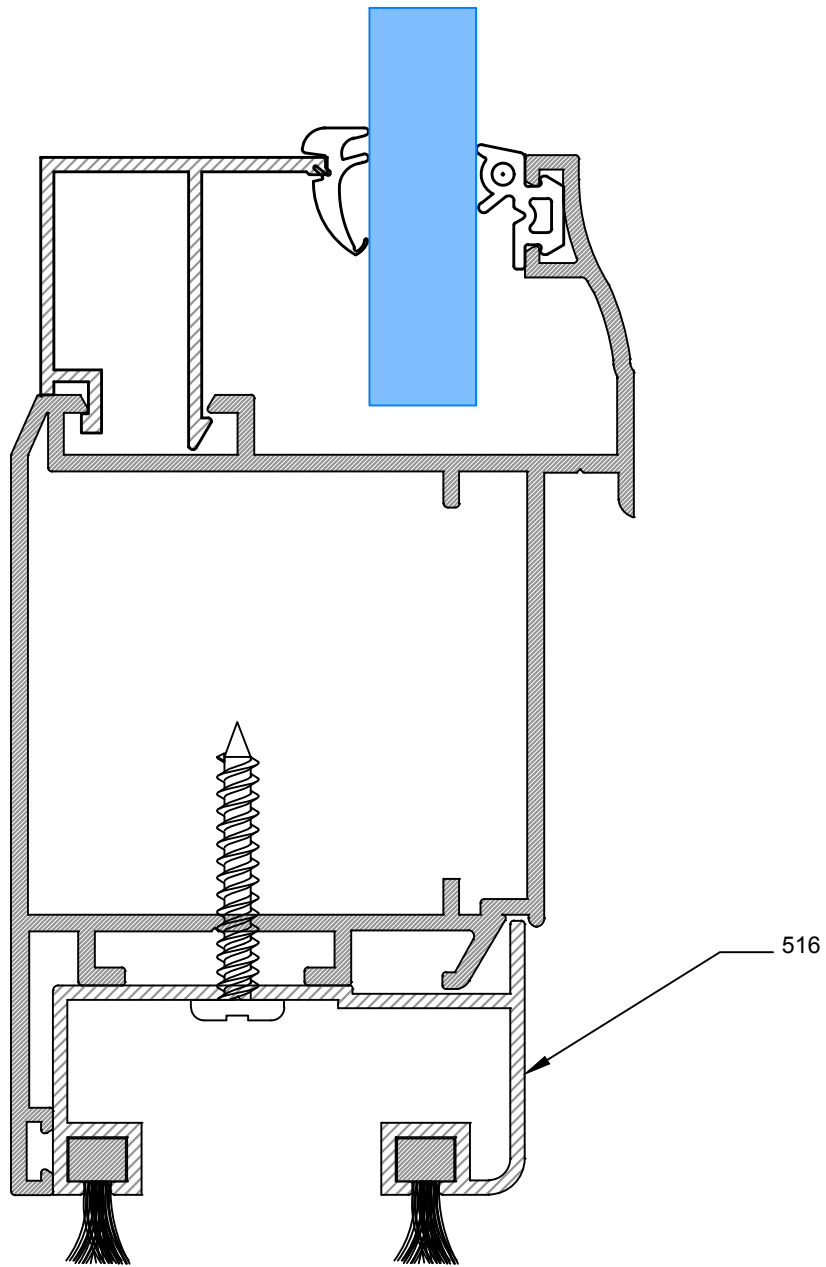

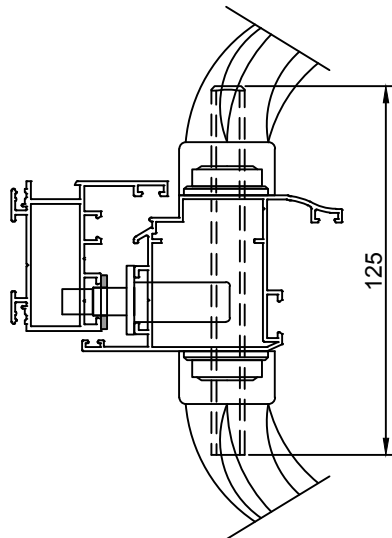
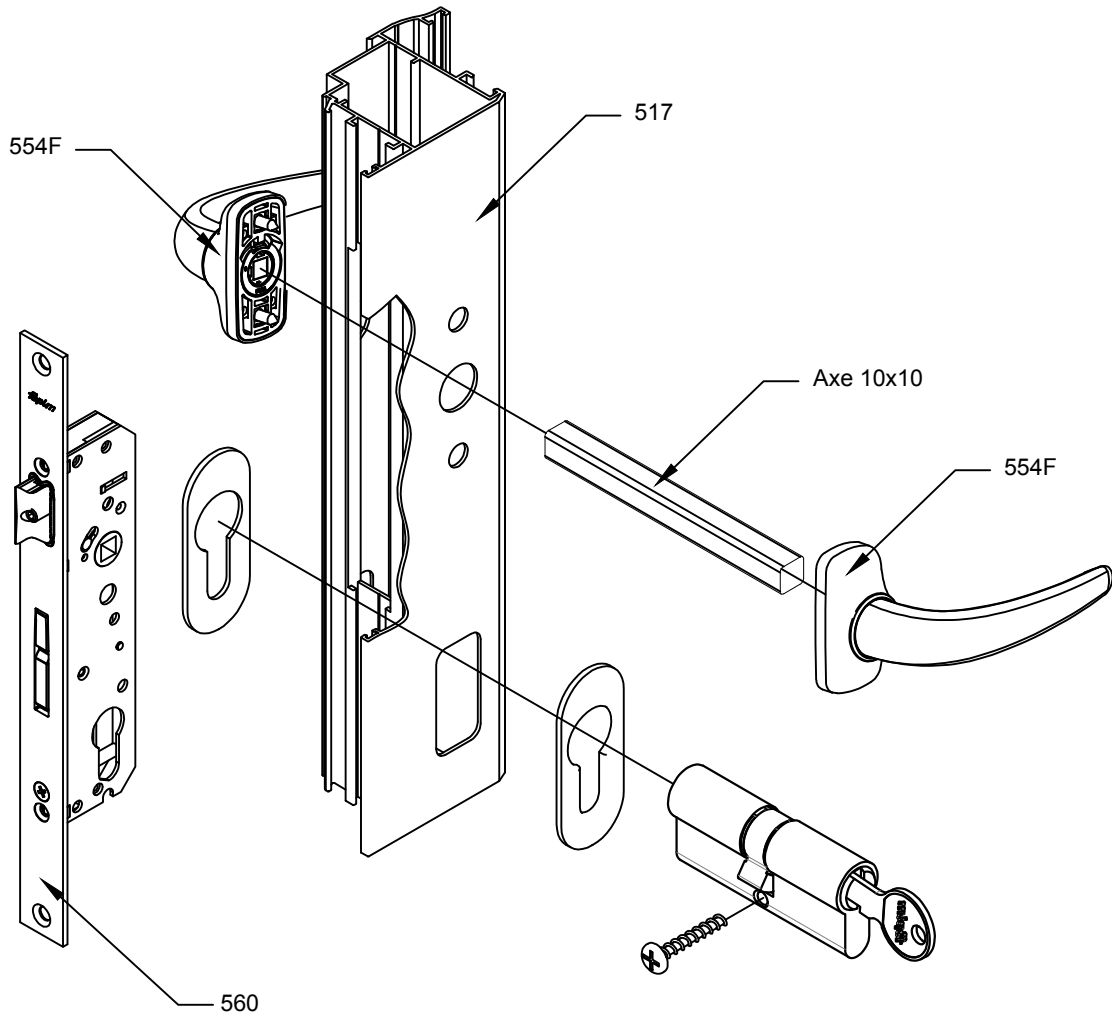

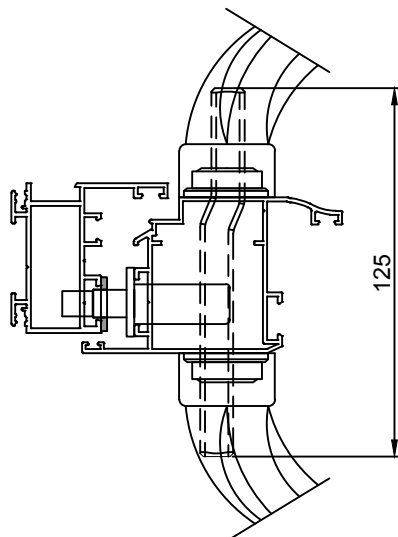
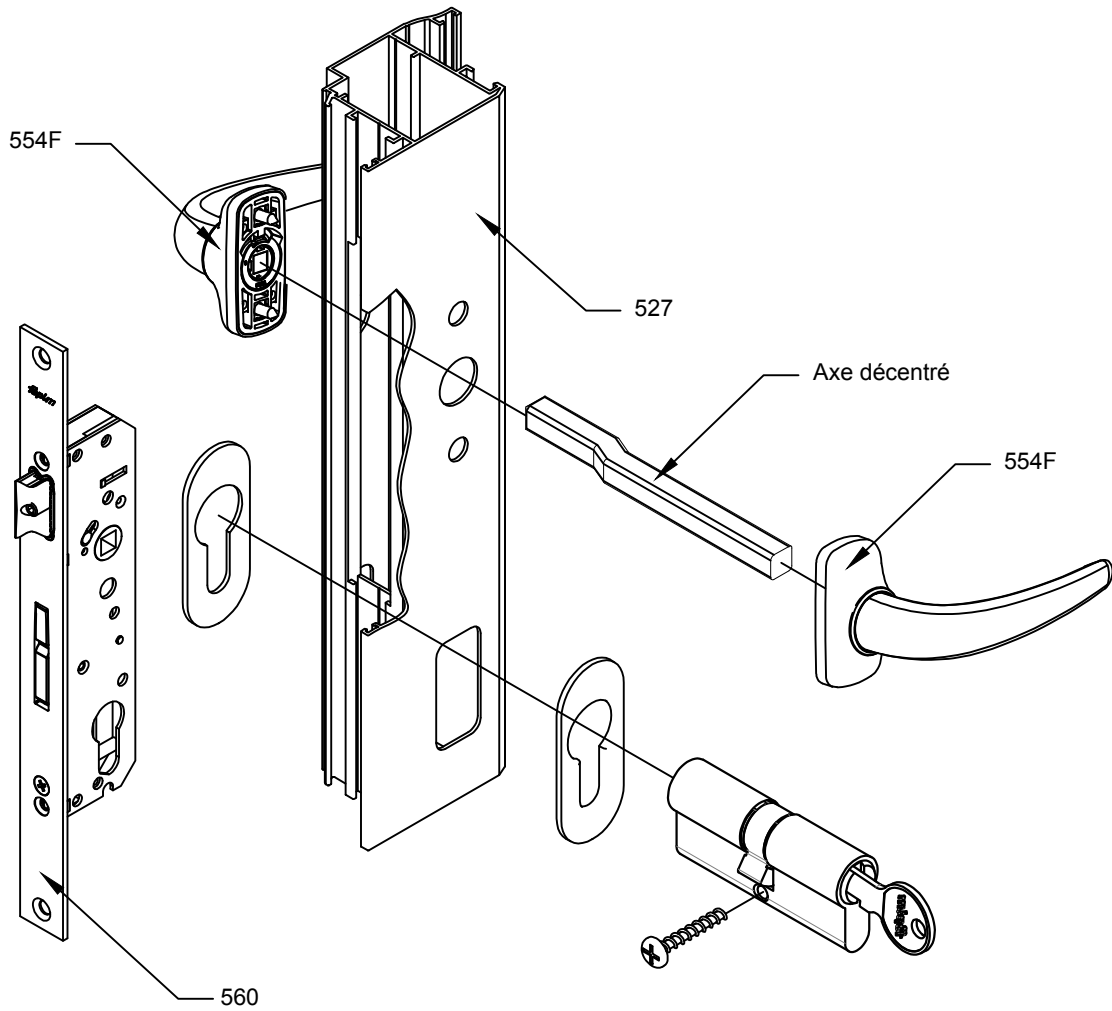

SERRURE REF 560

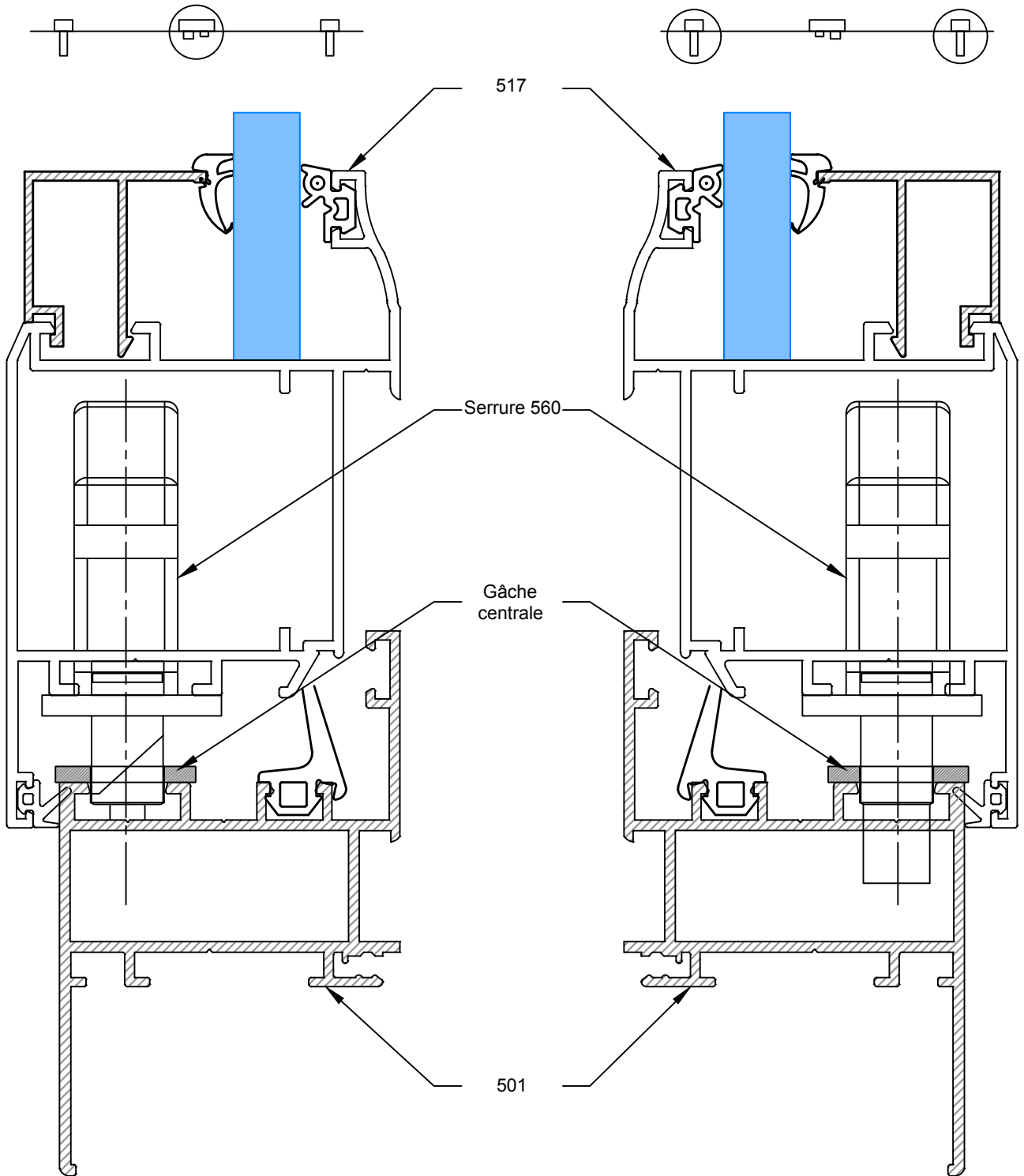

DEBITS ET COUPES

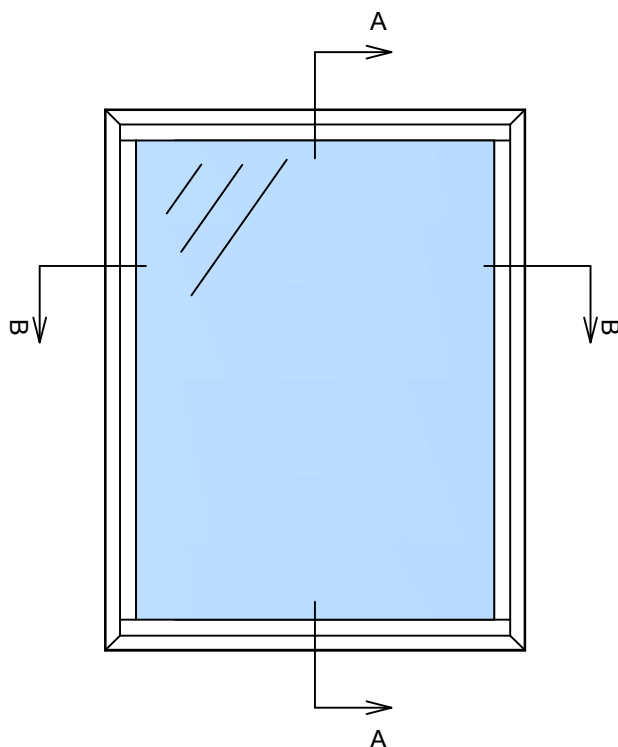

PROFILES
ACCESSOIRES

REF.	QTE	DESIGNATION	COUPE	DEBIT	REF.	QTE	DESIGNATION
500	2	DORMANT SANS C.J.	45°	L	E36-14	4	EQUERRE A PION
500	2	DORMANT SANS C.J.	45°	H			
	2	PARCLOSE	90°	L-54			
	2	PARCLOSE	90°	H-93.8			
		COTES DE VITRAGE					
		L-64			592	2L+2H	JOINTS
		H-64			594-595	2L+2H	JOINT FEUILLURE
							JOINT DE VITRAGE

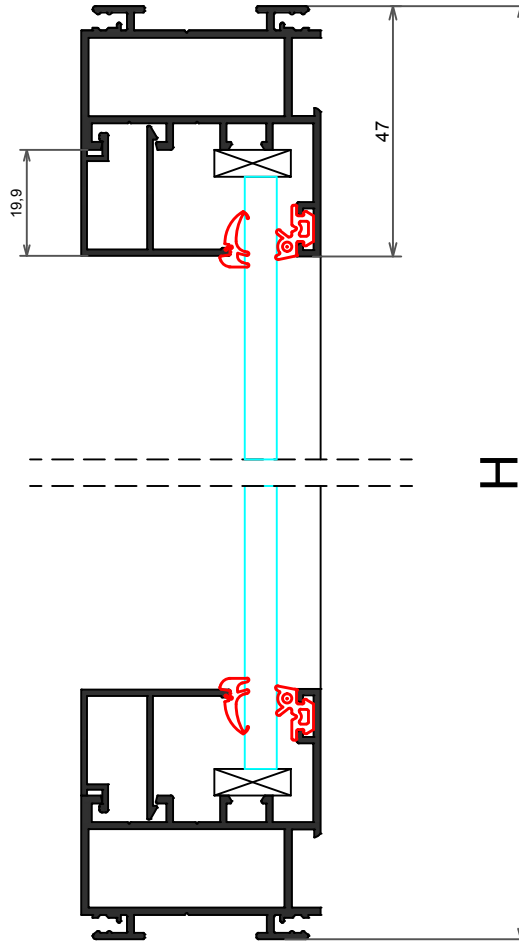
COUPE A-A

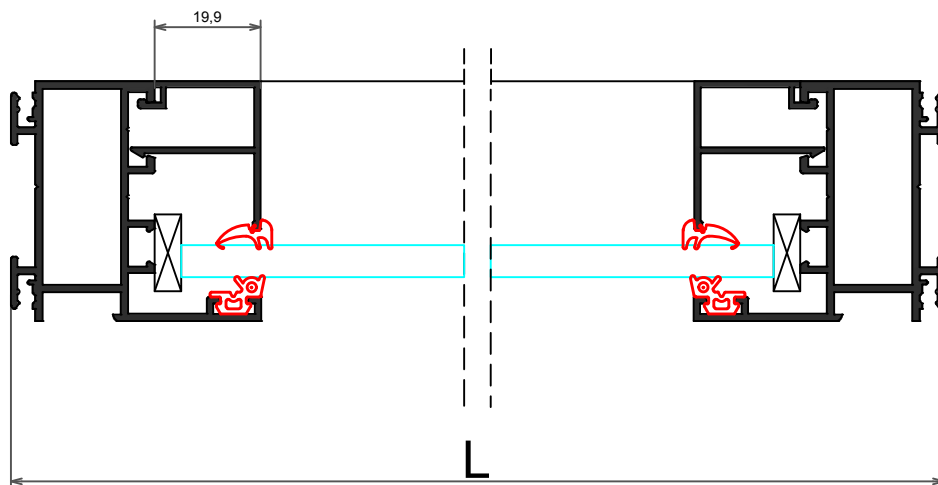

COUPE B-B



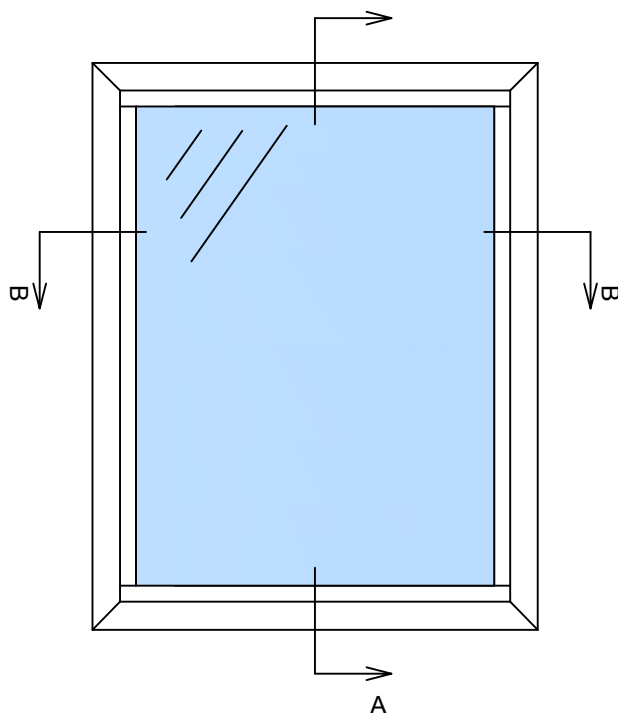

PROFILES
ACCESSOIRES

REF.	QTE	DESIGNATION	COUPE	DEBIT	REF.	QTE	DESIGNATION
501	2	DORMANT AVEC C.J.	45°	L+50	E36-14	4	EQUERRE A PION
501	2	DORMANT AVEC C.J.	45°	H+50			
	2	PARCLOSE	90°	L-54			
	2	PARCLOSE	90°	H-93.8			
		COTES DE VITRAGE					
		L-64			592	2L+2H	JOINTS
		H-64			594-595	2L+2H	JOINT FEUILLURE
							JOINT DE VITRAGE

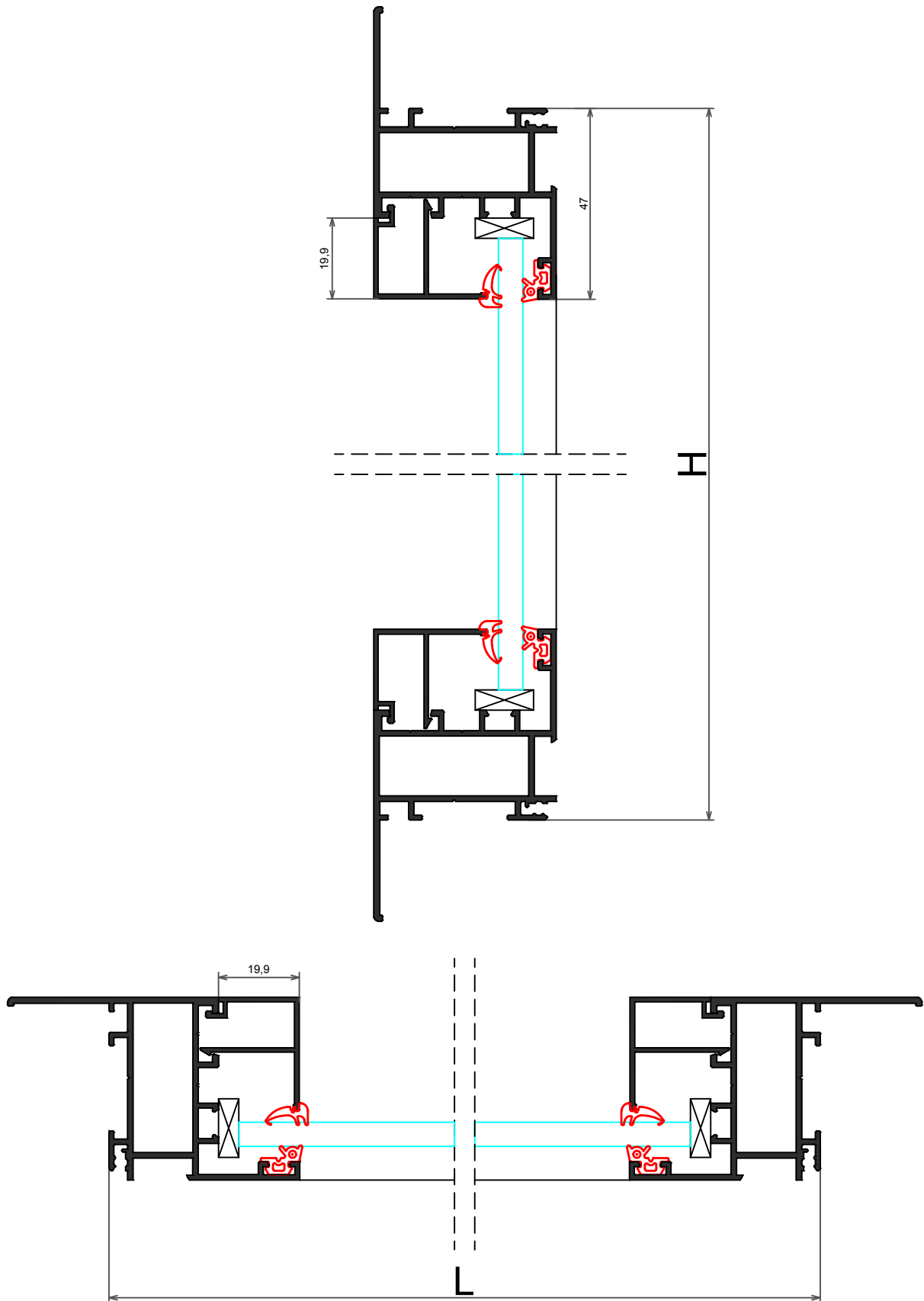
COUPE CHASSIS FIXE D.A.C.J.

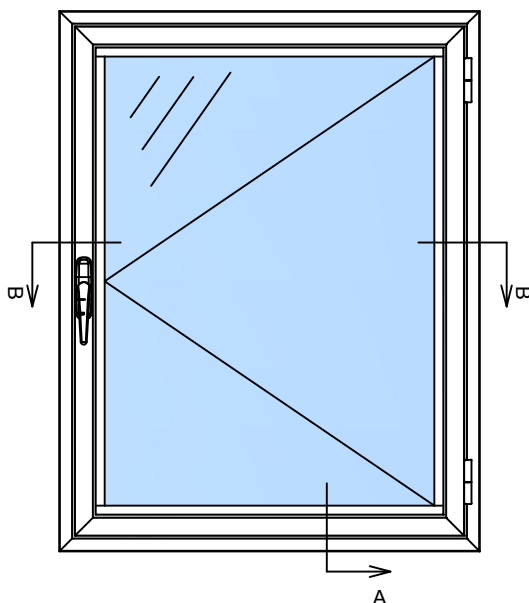



PROFILES
ACCESSOIRES

REF.	QTE	DESIGNATION	COUPE	DEBIT	REF.	QTE	DESIGNATION
500	2	DORMANT SANS C.J.	45°	L	E36-14	8	EQUERRE A PION
500	2	DORMANT SANS C.J.	45°	H	553F	2-3	PAUMELLES
507	2	Z OUVRANT	45°	L-42	OPTION 1		
507	2	Z OUVRANT	45°	H-42	OPTION 1		
	2	PARCLOSE	90°	L-131	555F	1	POIGNEE ANGLAISE
	2	PARCLOSE	90°	H-170.8	OPTION 2		
					557F	1	CREMONE 2 FOURCHES
					557/ET	2	EMBOUT DE TRINGLE
					557/PA	1	PAIR D'ENTRAINEUR POUR CREMONE
					557/G	1	GACHE DOUBLE
					OPTION 3		
					556/F	1	CREMONE 1 FOURCHE
					556/EL	1	556/EL OU 556/AR
					556/GUI	2	GACHE UNIVERSEL INDUSTRIEL
					556/SUP	2	AXE DE FERMETURE SUPLEMENTAIRE
					JOINTS		
					592	2L+2H	JOINT DE BATTUE
					594-595	2L+2H	JOINT DE VITRAGE
					593	2L+2H	JOINT FEUILLURE
					596	2L+2H	JOINT DORMANT
					591	2L+2H	JOINT FROID CENTRALE
		COTES DE VITRAGE L-131 H-131					

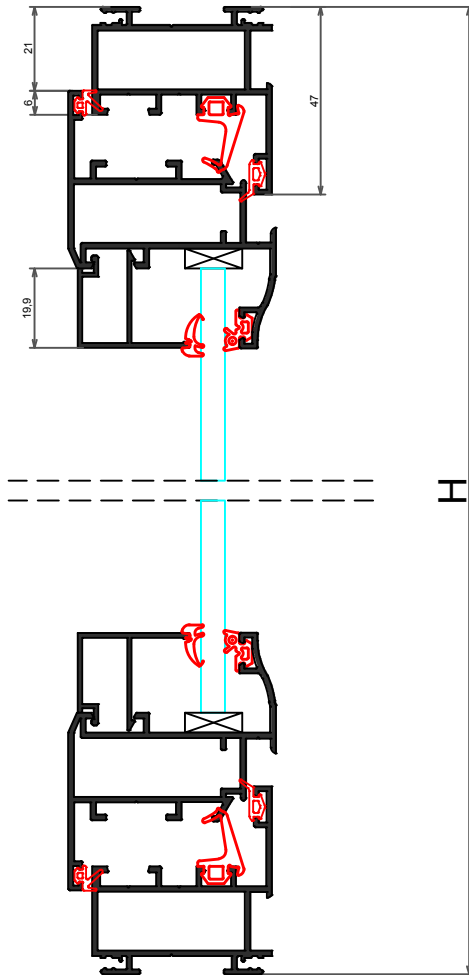
COUPE A-A

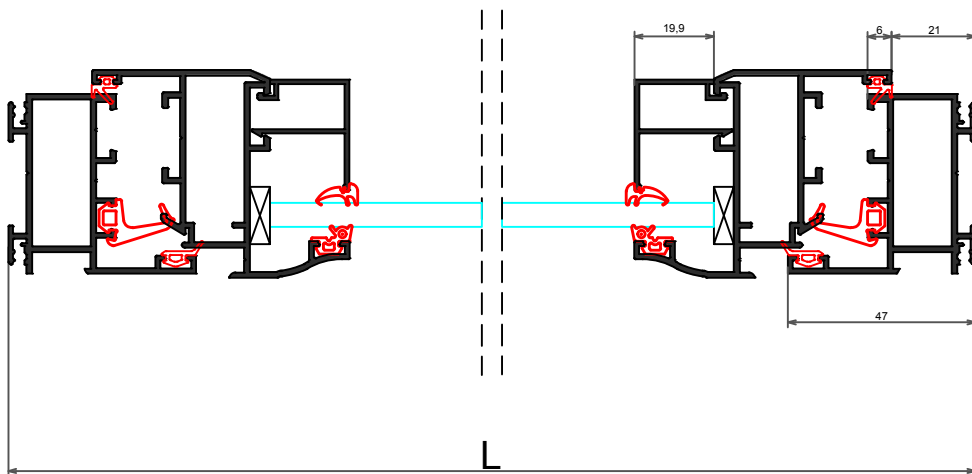

COUPE B-B



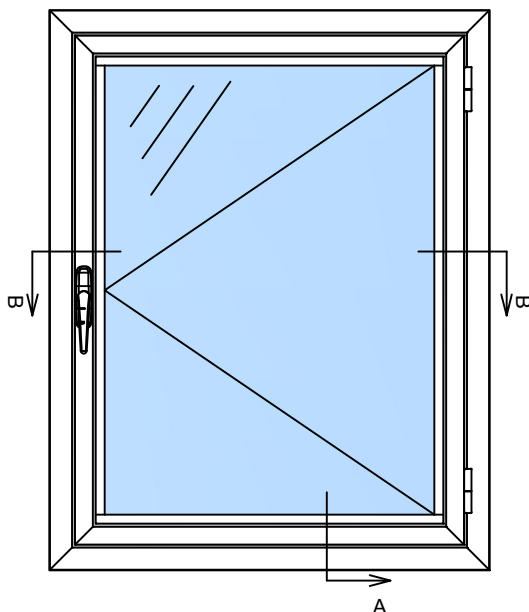

PROFILES
ACCESSOIRES

REF.	QTE	DESIGNATION	COUPE	DEBIT	REF.	QTE	DESIGNATION
501	2	DORMANT AVEC C.J.	45°	L+50	E36-14	8	EQUERRE A PION
501	2	DORMANT AVEC C.J.	45°	H+50	553F	2-3	PAUMELLES
507	2	Z OUVRANT	45°	L-42	OPTION 1		
507	2	Z OUVRANT	45°	H-42	555F	1	POIGNEE ANGLAISE
	2	PARCLOSE	90°	L-131	OPTION 2		
	2	PARCLOSE	90°	H-170.8	557F	1	CREMONE 2 FOURCHES
					557/ET	2	EMBOUT DE TRINGLE
					557/PA	1	PAIR D'ENTRAINEUR POUR CREMONE
					557/G	1	GACHE DOUBLE
					OPTION 3		
					556/F	1	CREMONE 1 FOURCHE
					556/EL	1	556/EL OU 556/AR
					556/GUI	2	GACHE UNIVERSEL INDUSTRIEL
					556/SUP	2	AXE DE FERMETURE SUPLEMENTAIRE
					JOINTS		
					592	2L+2H	JOINT DE BATTUE
					594-595	2L+2H	JOINT DE VITRAGE
					593	2L+2H	JOINT FEUILLURE
					596	2L+2H	JOINT DORMANT
					591	2L+2H	JOINT FROID CENTRALE
		COTES DE VITRAGE L-131 H-131					

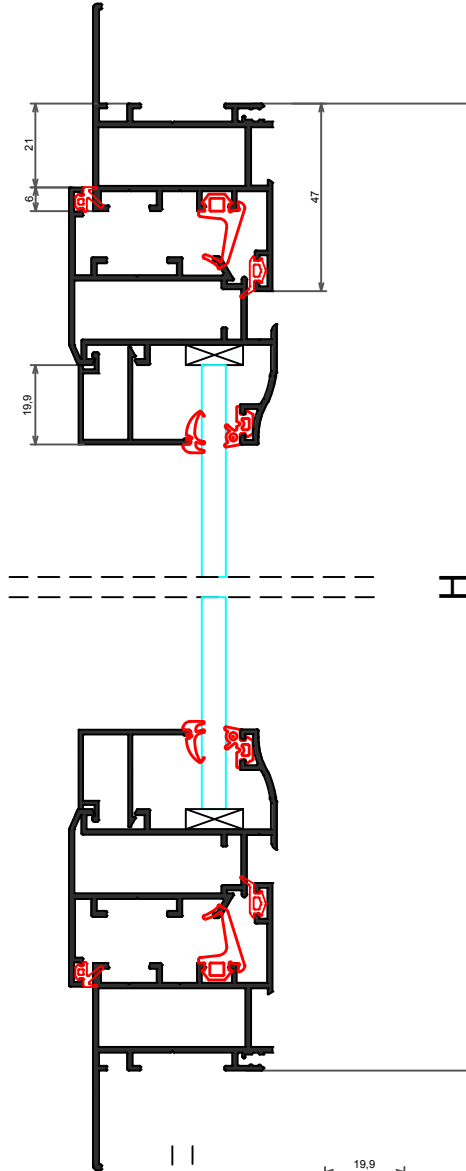
COUPE A-A

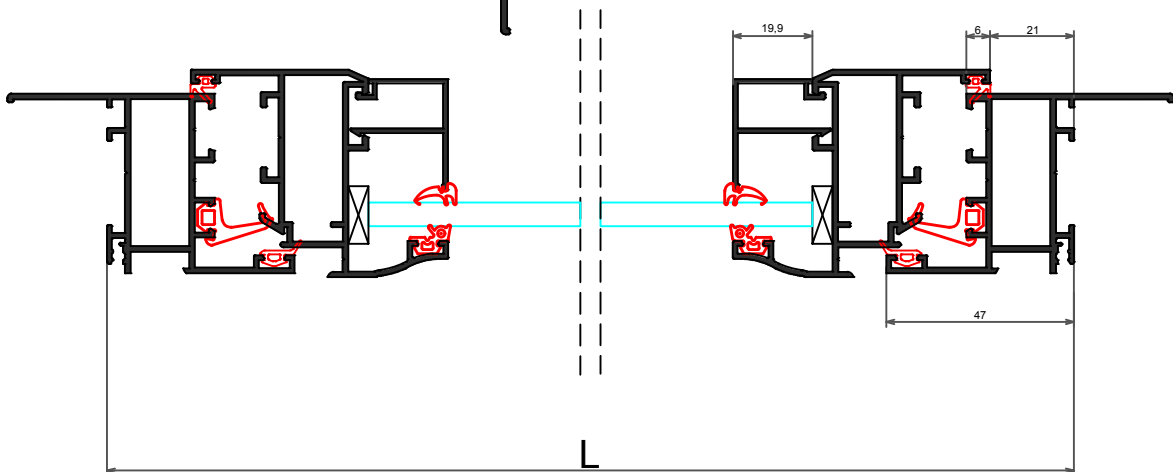

COUPE B-B



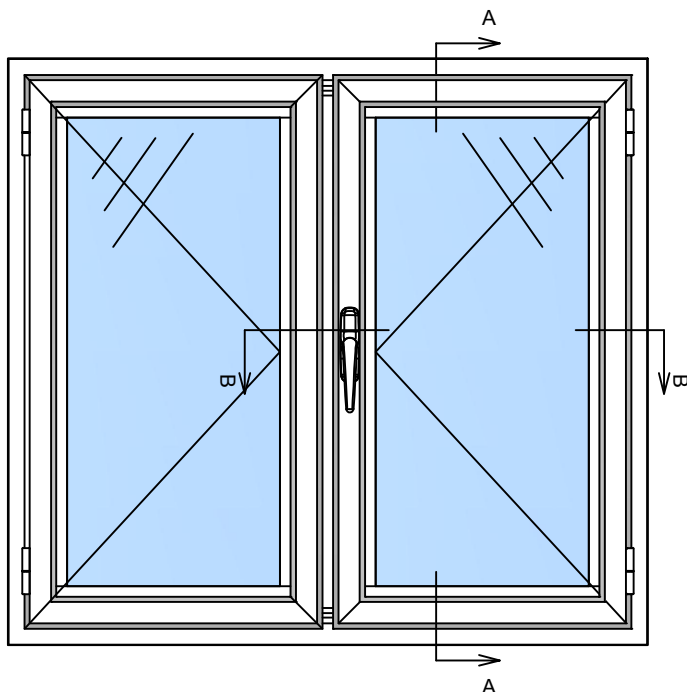

PROFILES
ACCESSOIRES

REF.	QTE	DESIGNATION	COUPE	DEBIT	REF.	QTE	DESIGNATION
500	2	DORMANT SANS C.J.	45°	L	E36-14	12	EQUERRE A PION
500	2	DORMANT SANS C.J.	45°	H	553F	4-6	PAUMELLES
503	1	TRINGLE OUVRANT	90°	H	OPTION 1		
507	4	OUVRANT FENETRE	45°	L/2-13.2	555F	1	POIGNEE ANGLAISE
507	3	OUVRANT FENETRE	45°	H-42	561F/220	2	VERROU POUR SEMI-FIXE
509	1	INVERSEUR FENETRE	45°	H-42	557/G	1	GACHE DOUBLE
	4	PARCLOSE	90°	L/2-102.2	OPTION 2		
	4	PARCLOSE	90°	H-170.8	557F	1	CREMONE 2 FOURCHES
					557/ET	2	EMBOUT DE TRINGLE
					557/PA	1	PAIR D'ENTRAINEUR POUR CREMONE
					557/G	1	GACHE DOUBLE
					561F/220	2	VERROU POUR SEMI-FIXE
					557/G	1	GACHE DOUBLE
					OPTION 3		
					556/F	1	CREMONE 1 FOURCHE
						1	556/EL OU 556/AR
					556/GUI	2	GACHE UNIVERSEL INDUSTRIEL
					556/SUP	2	AXE DE FERMETURE SUPLEMENTAIRE
					561F/220	2	VERROU POUR SEMI-FIXE
					557G	1	GACHE DOUBLE
					JOINTS		
					592	2L+3H	JOINT DE BATTUE
					594-595	2L+4H	JOINT DE VITRAGE
					593	2L+4H	JOINT FEUILLURE
					596	2L+3H	JOINT DORMANT
					591	2L+3H	JOINT FROID CENTRALE
		COTES DE VITRAGE H-131 L/2-102.2					

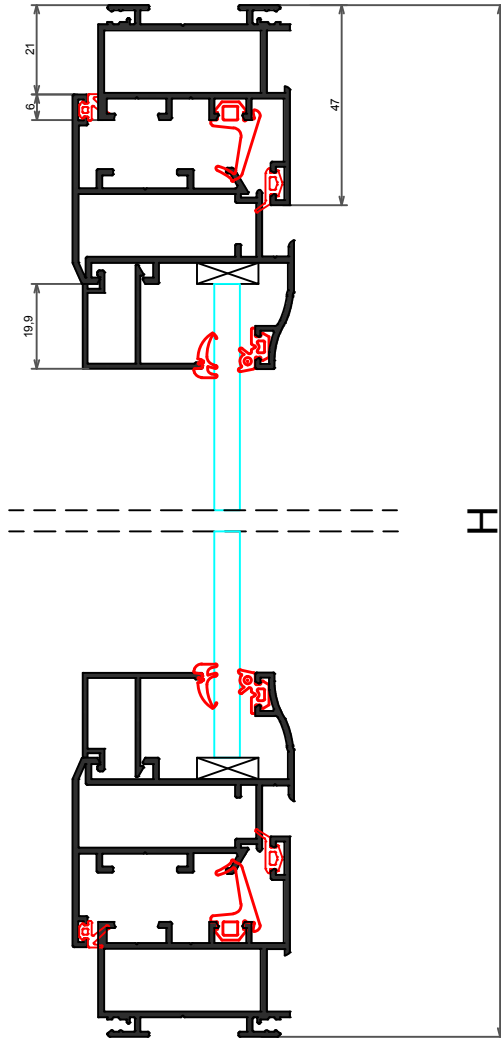
COUPE A-A

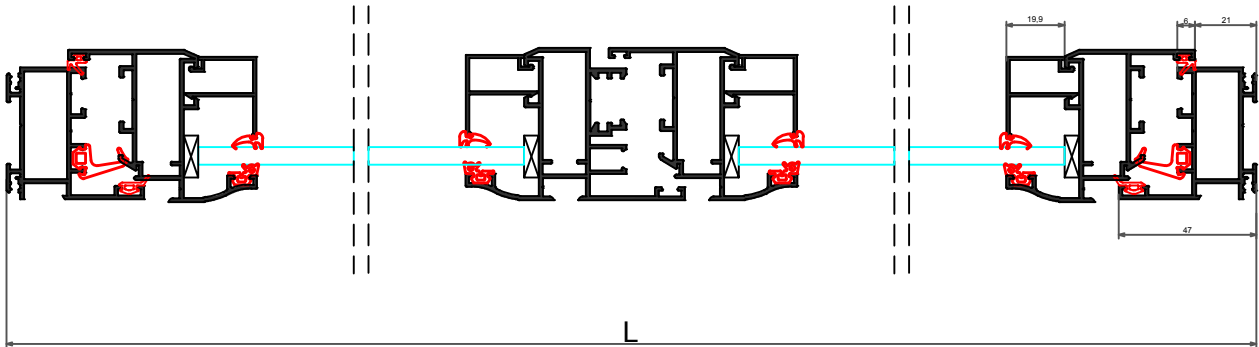

COUPE B-B



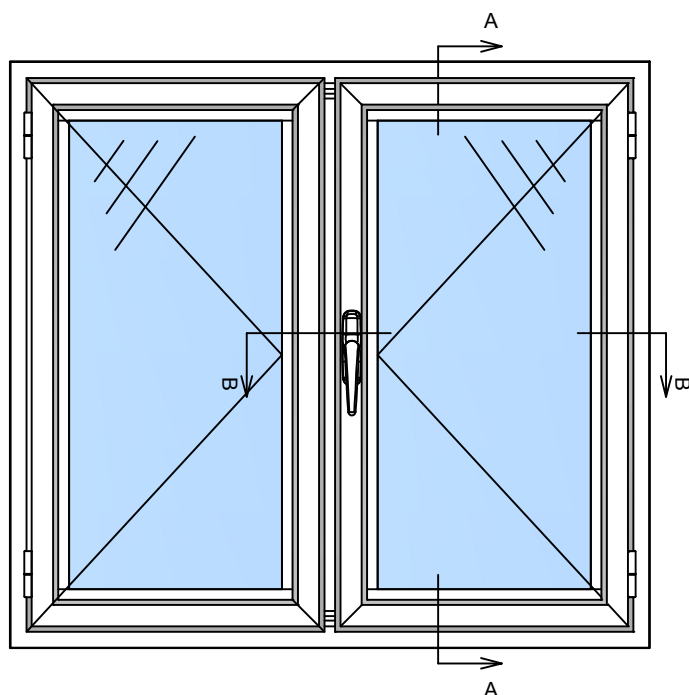

PROFILES
ACCESSOIRES

REF.	QTE	DESIGNATION	COUPE	DEBIT	REF.	QTE	DESIGNATION
501	2	DORMANT AVEC C.J.	45°	L+50	E36-14	12	EQUERRE A PION
501	2	DORMANT AVEC C.J.	45°	H+50	553F	4-6	PAUMELLES
503		TRINGLE OUVRANT	90°	H	OPTION 1		
507	4	OUVRANT FENETRE	45°	L/2-13.2	555F	1	POIGNEE ANGLAISE
507	3	OUVRANT FENETRE	45°	H-42	561F/220	2	VERROU POUR SEMI-FIXE
509	1	INVERSEUR FENETRE	45°	H-42	557/G	1	GACHE DOUBLE
	4	PARCLOSE	90°	L/2-102.2	OPTION 2		
	4	PARCLOSE	90°	H-170.8	557F	1	CREMONE 2 FOURCHES
					557/ET	2	EMBOUT DE TRINGLE
					557/PA	1	PAIR D'ENTRAINEUR POUR CREMONE
					557/G	1	GACHE DOUBLE
					561F/220	2	VERROU POUR SEMI-FIXE
					557/G	1	GACHE DOUBLE
					OPTION 3		
					556/F	1	CREMONE 1 FOURCHE
						1	556/EL OU 556/AR
					556/GUI	2	GACHE UNIVERSEL INDUSTRIEL
					556/SUP	2	AXE DE FERMETURE SUPLEMENTAIRE
					561F/220	2	VERROU POUR SEMI-FIXE
					557G	1	GACHE DOUBLE
					JOINTS		
					592	2L+3H	JOINT DE BATTUE
					594-595	2L+4H	JOINT DE VITRAGE
					593	2L+4H	JOINT FEUILLURE
					596	2L+3H	JOINT DORMANT
					591	2L+3H	JOINT FROID CENTRALE
		COTES DE VITRAGE H-131 L/2-102.2					

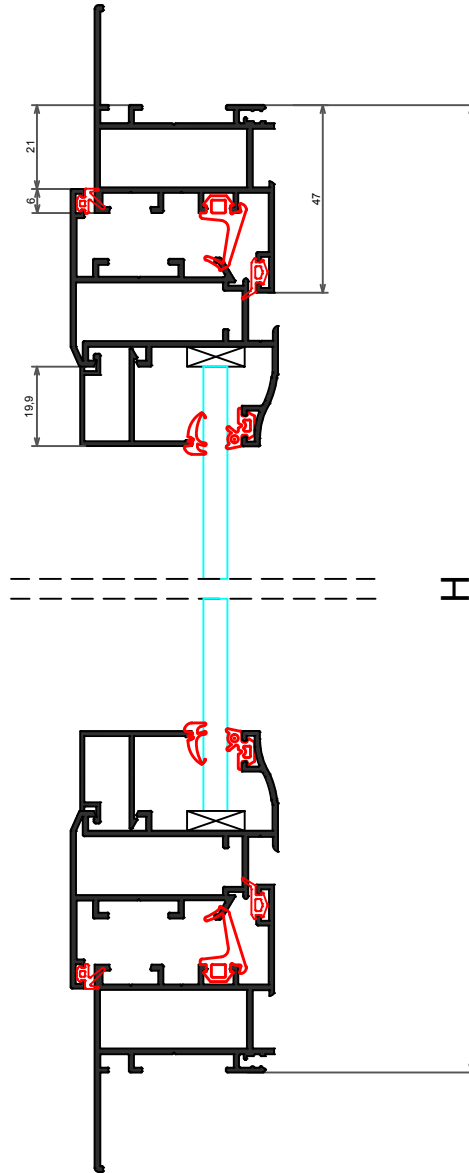
COUPE A-A

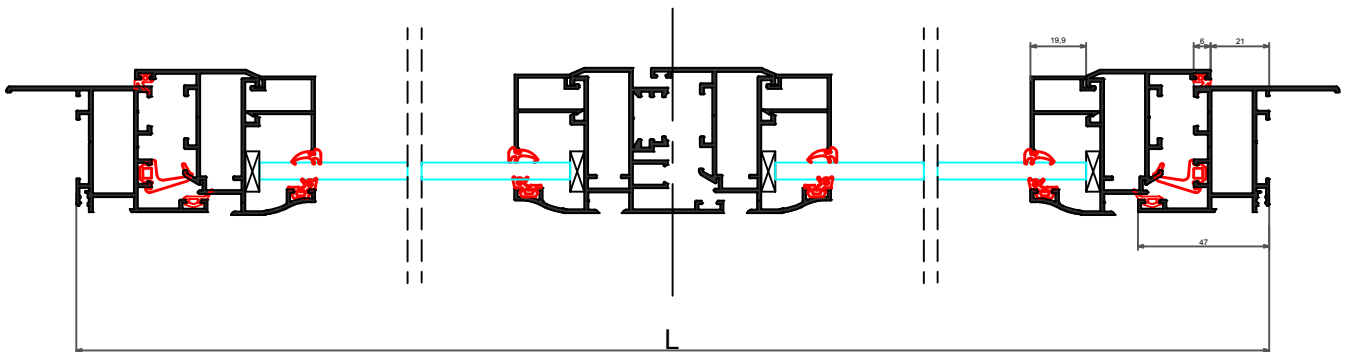

COUPE B-B



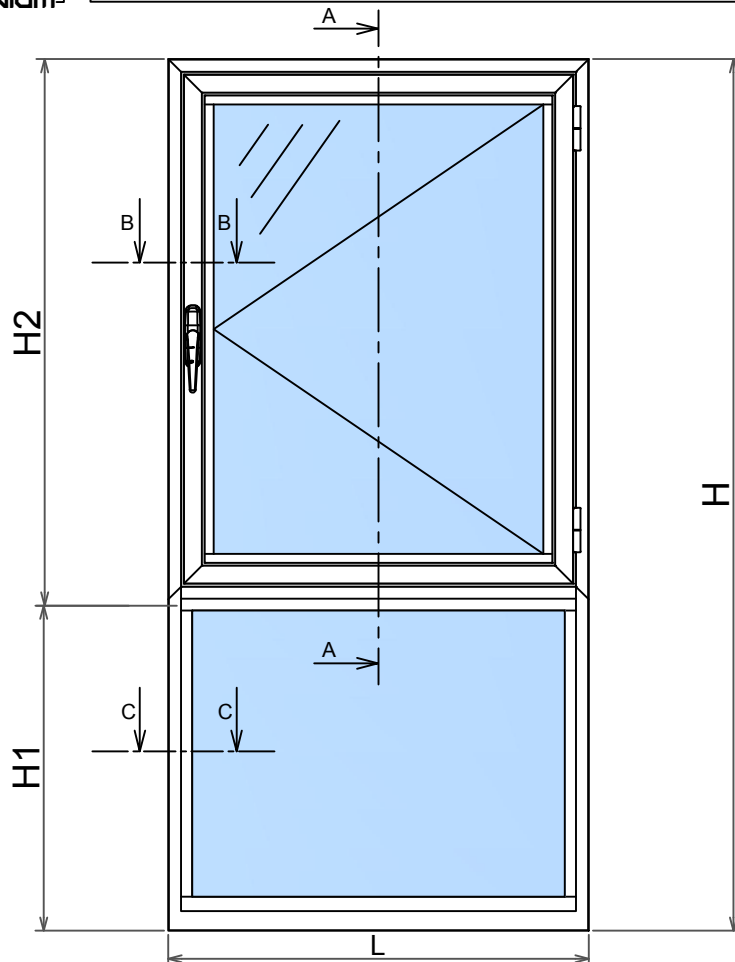

PROFILES
ACCESSOIRES

REF.	QTE	DESIGNATION	COUPE	DEBIT	REF.	QTE	DESIGNATION
500	2	DORMANT SANS C.J.	45°	L	E36-14	8	EQUERRE A PION
500	2	DORMANT SANS C.J.	45°	H=H1+H2	553F	2-3	PAUMELLES
507	2	Z OUVRANT	45°	L-42	OPTION 1		
507	2	Z OUVRANT	45°	H-28.65			
505	1	TRAVERSE	90°	L-54	555F	1	POIGNEE ANGLAISE
	2	PARCLOSE OUVRANT	90°	H-131	OPTION 2		
	2	PARCLOSE OUVRANT	90°	H2-157.5	557F	1	CREMONE 2 FOURCHES
	2	PARCLOSE FIXE	90°	L-54	557/ET	2	EMBOUT DE TRINGLE
	2	PARCLOSE FIXE	90°	L-80.5	557/PA	1	PAIR D'ENTRAINEUR POUR CREMONE
					557/G	1	GACHE DOUBLE
					OPTION 3		
					556/F	1	CREMONE 1 FOURCHE
					556/EL	1	556/EL OU 556/AR
		COTES DE VITRAGE			556/GUI	2	GACHE UNIVERSEL INDUSTRIEL
		VITRAGE OUVRANT		L-131	556/SUP	2	AXE DE FERMETURE SUPLEMENTAIRE
				H-117.65	562	2	CAVALIER POUR TRAVERSE DE 70
		VITRAGE FIXE		L-64			
				H-50.65			
					592	2L+2H2	JOINTS
					594-595	4L+2H1+2H2	JOINT DE BATTUE
					593	4L+2H1+2H2	JOINT DE VITRAGE
					596	2L+2H2	JOINT FEUILLURE
					591	2L+2H2	JOINT DORMANT
							JOINT FROID CENTRALE

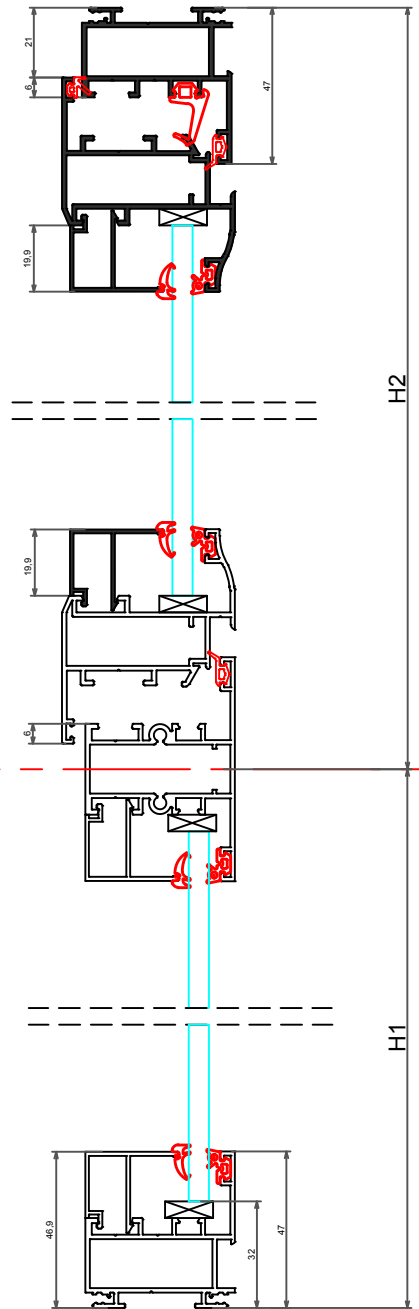
COUPE A-A

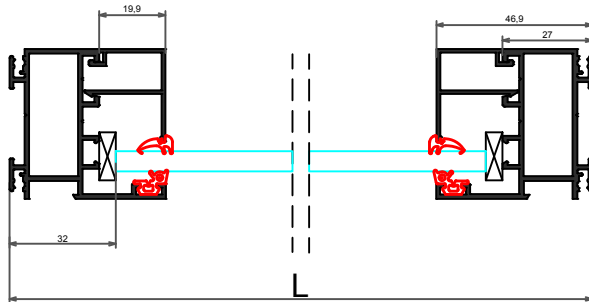

COUPE C-C



COUPE B-B

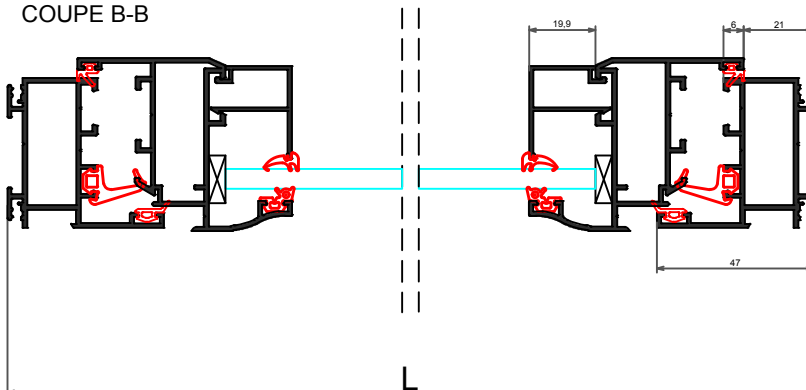

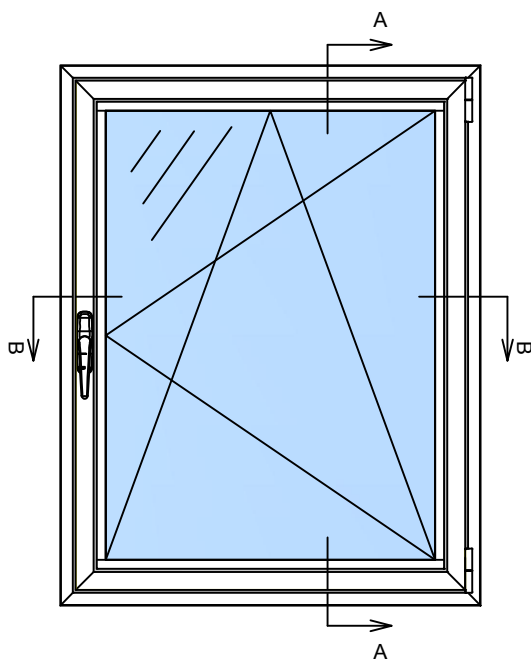

PROFILES
ACCESSOIRES

REF.	QTE	DESIGNATION	COUPE	DEBIT	REF.	QTE	DESIGNATION
500	2	DORMANT SANS C.J.	45°	L	E36-14	8	EQUERRE A PION
500	2	DORMANT SANS C.J.	45°	H	567F	1	PAUMELLE ESCILO-BATTANT
507	2	Z OUVRANT	45°	L-42	568F		
507	2	Z OUVRANT	45°	H-42	OU	1	KIT OSCILO-BATTANT
	2	PARCLOUSE	90°	L-131	568F/GL		
	2	PARCLOUSE	90°	H-170.8	565F	1	COMPAS POUR OSCILO-BATTANT
					554F	1	CREMONE 1 FOURCHE
						1	556/EL OU 556/AR
		COTES DE VITRAGE					JOINTS
		L-131			592	2L+3H	JOINT DE BATTUE
		H-131			594-595	2L+2H	JOINT DE VITRAGE
					593	2L+2H	JOINT FEUILLURE
					596	2L+2H	JOINT DORMANT
					591	2L+2H	JOINT FROID CENTRALE

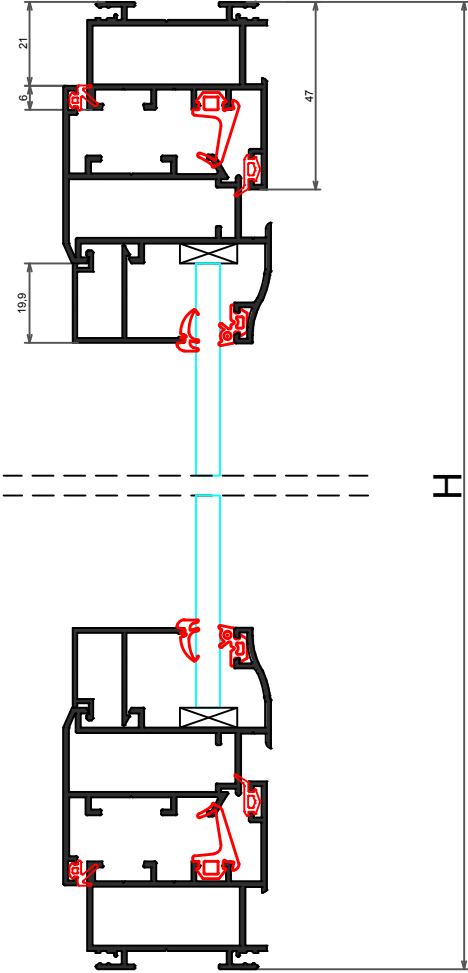
COUPE A-A

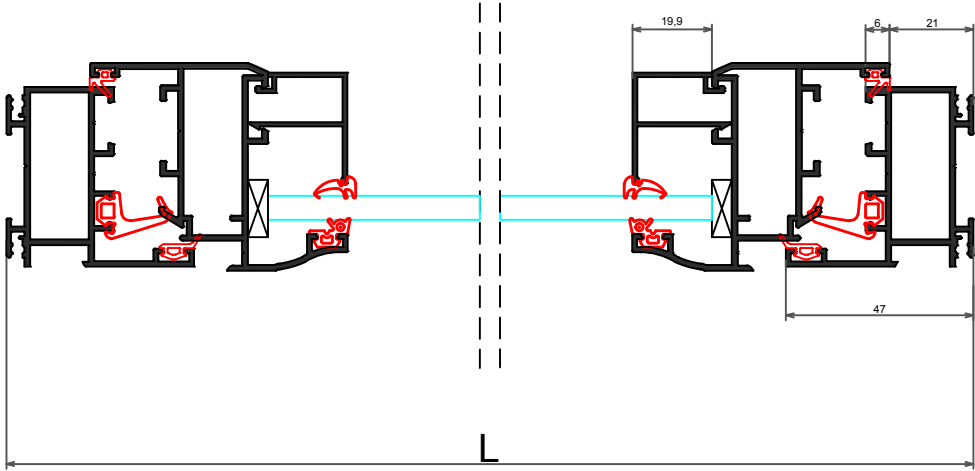

COUPE B-B



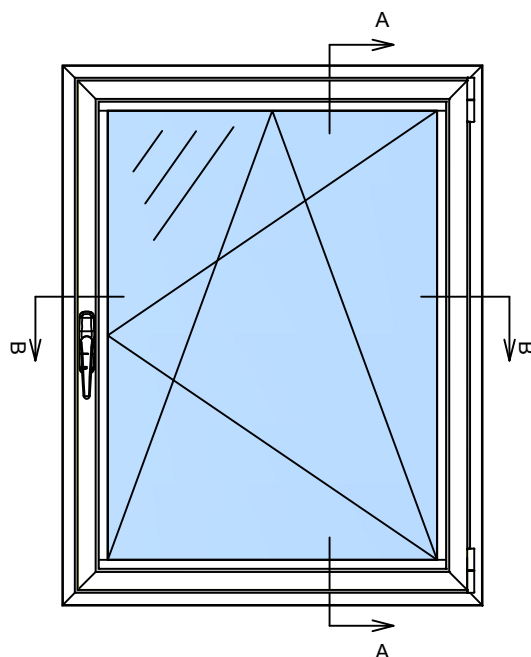

PROFILES
ACCESSOIRES

REF.	QTE	DESIGNATION	COUPE	DEBIT	REF.	QTE	DESIGNATION
501	2	DORMANT AVEC C.J.	45°	L+50	E36-14	8	EQUERRE A PION
501	2	DORMANT AVEC C.J.	45°	H+50	567F	1	PAUMELLE ESCILO-BATTANT
507	2	Z OUVRANT	45°	L-42	568F		
507	2	Z OUVRANT	45°	H-42	OU	1	KIT OSCILO-BATTANT
	2	PARCLOSE	90°	L-131	568F/GL		
	2	PARCLOSE	90°	H-170.8	565F	1	COMPAS POUR OSCILO-BATTANT
					554F	1	CREMONE 1 FOURCHE
						1	556/EL OU 556/AR
		COTES DE VITRAGE					JOINTS
		L-131			592	2L+3H	JOINT DE BATTUE
		H-131			594-595	2L+2H	JOINT DE VITRAGE
					593	2L+2H	JOINT FEUILLURE
					596	2L+2H	JOINT DORMANT
					591	2L+2H	JOINT FROID CENTRALE

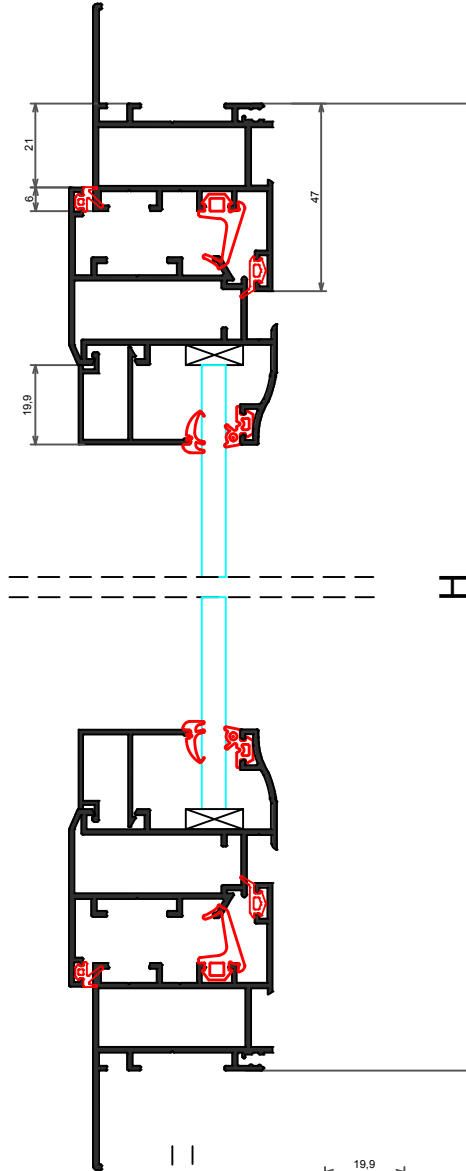
COUPE A-A

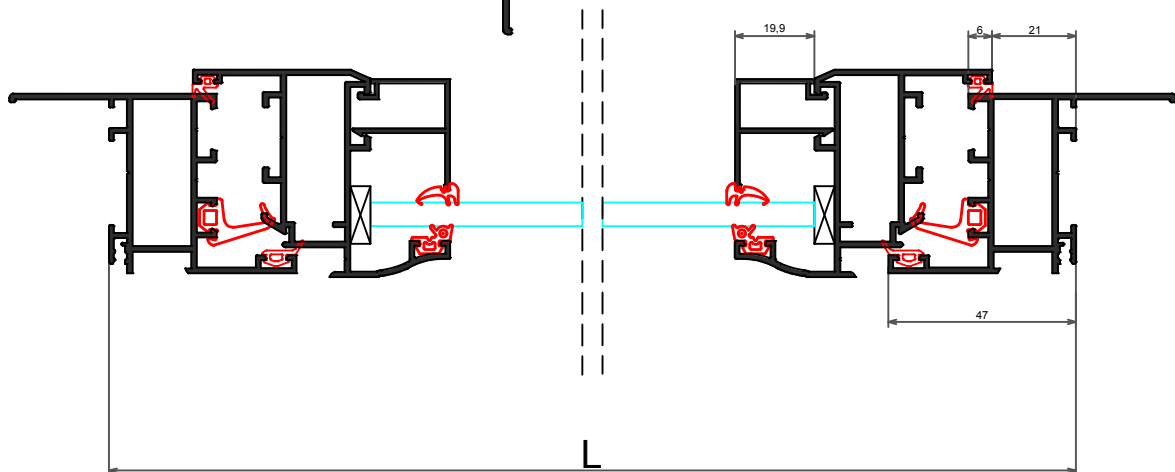

COUPE B-B



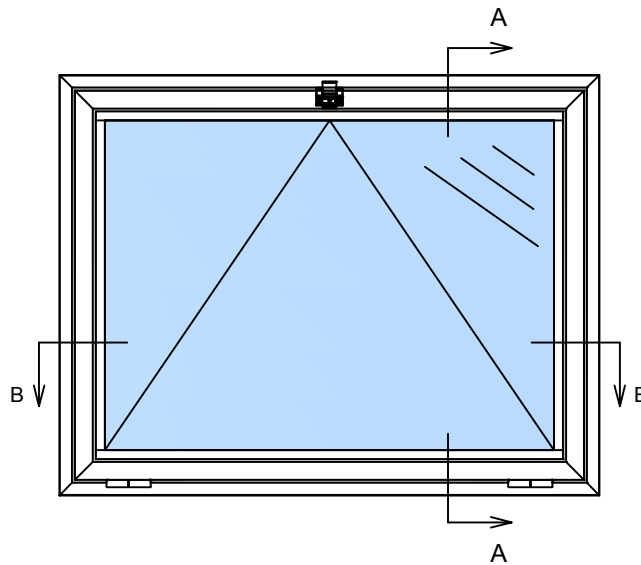

PROFILES

ACCESSOIRES

REF.	QTE	DESIGNATION	COUPE	DEBIT	REF.	QTE	DESIGNATION
500	2	DORMANT SANS C.J.	45°	L	E36-14	8	EQUERRE A PION
500	2	DORMANT SANS C.J.	45°	H	553F	2-3	PAUMELLES
507	2	Z OUVRANT	45°	L-42	558F	1	LOQUETEAU POUR SOUFFLET
507	2	Z OUVRANT	45°	H-42	559F-150		
	2	PARCLOSE	90°	L-131	OU	1-2	COMPAS POUR SOUFFLET
	2	PARCLOSE	90°	H-170.8	559F/220		
		COTES DE VITRAGE					
		L-131			592	2L+2H	JOINT DE BATTUE
		H-131			594-595	2L+2H	JOINT DE VITRAGE
					593	2L+2H	JOINT FEUILLURE
					596	2L+2H	JOINT DORMANT
					591	2L+2H	JOINT FROID CENTRALE

COUPE A-A

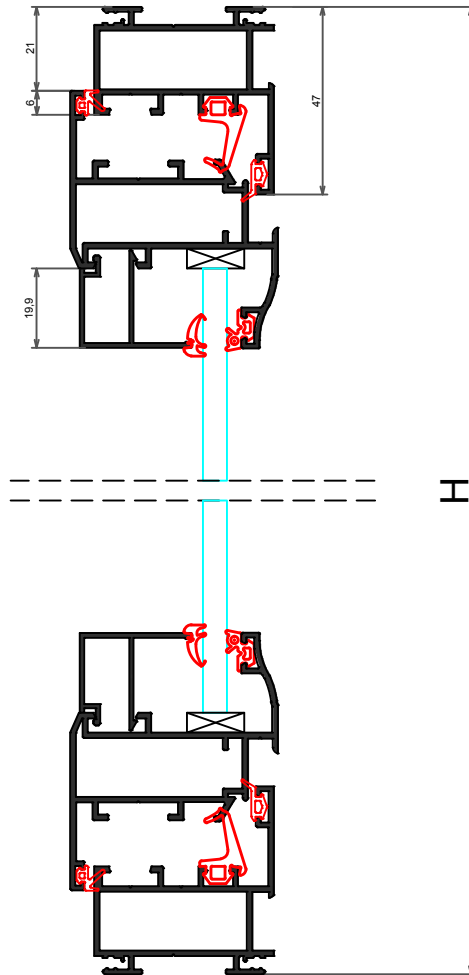

COUPE B-B

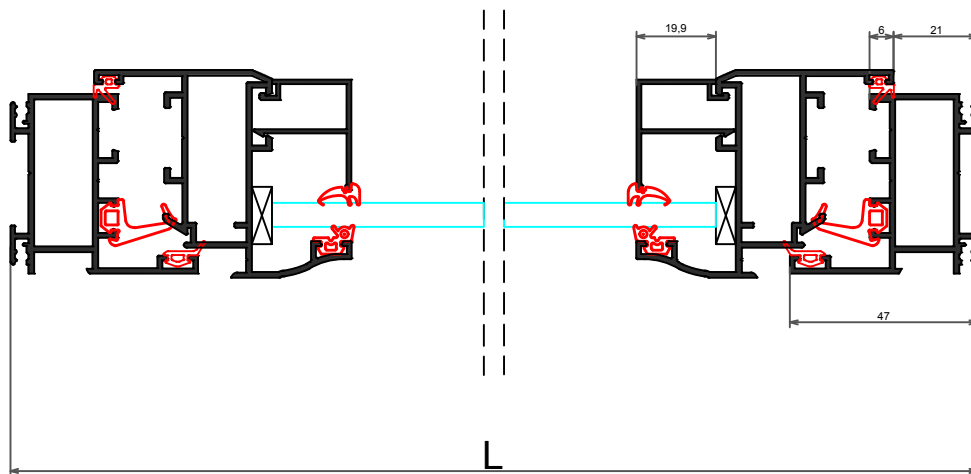

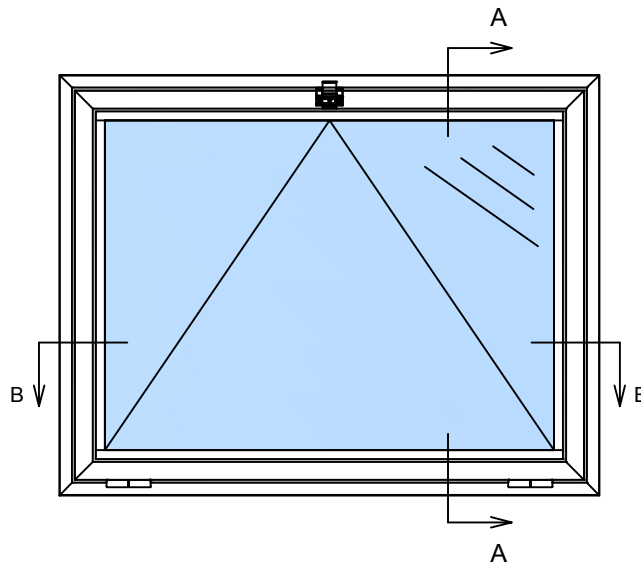

PROFILES

ACCESSOIRES

REF.	QTE	DESIGNATION	COUPE	DEBIT	REF.	QTE	DESIGNATION
501	2	DORMANT AVEC C.J.	45°	L+50	E36-14	8	EQUERRE A PION
501	2	DORMANT AVEC C.J.	45°	H+50	553F	2-3	PAUMELLES
507	2	Z OUVRANT	45°	L-42	558F	1	LOQUETEAU POUR SOUFFLET
507	2	Z OUVRANT	45°	H-42	559F-150		
	2	PARCLOSE	90°	L-131	OU	1-2	COMPAS POUR SOUFFLET
	2	PARCLOSE	90°	H-170.8	559F/220		
		COTES DE VITRAGE					
		L-131			592	2L+2H	JOINT DE BATTUE
		H-131			594-595	2L+2H	JOINT DE VITRAGE
					593	2L+2H	JOINT FEUILLURE
					596	2L+2H	JOINT DORMANT
					591	2L+2H	JOINT FROID CENTRALE

COUPE A-A

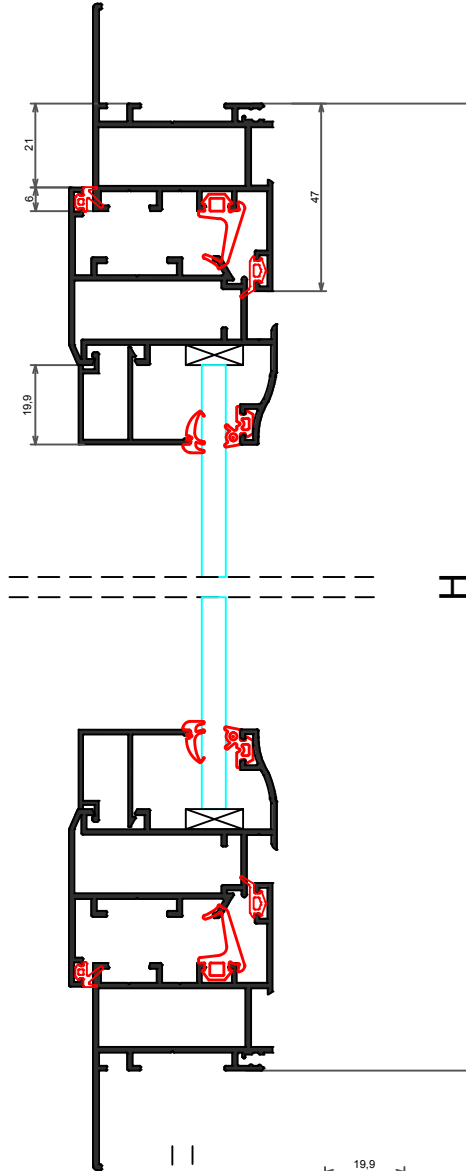

COUPE B-B

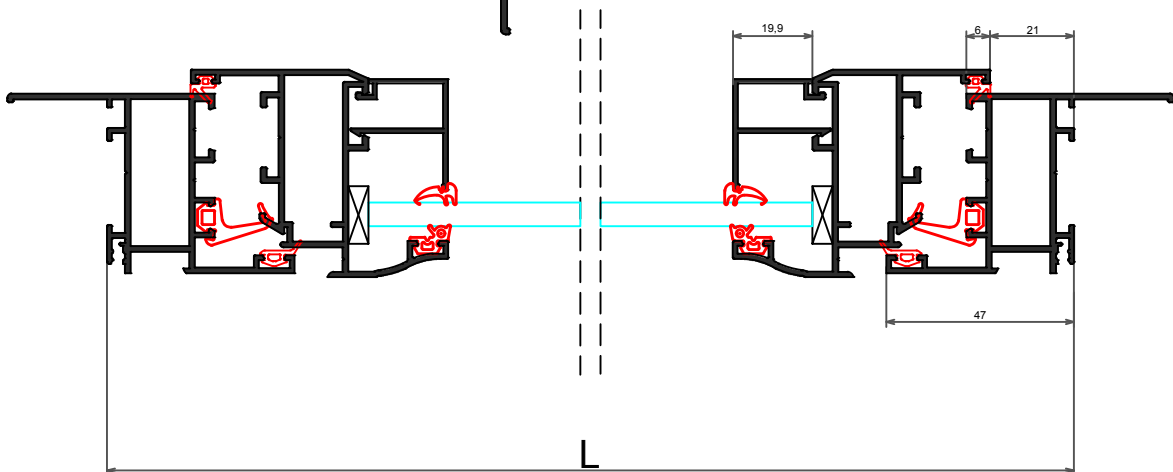

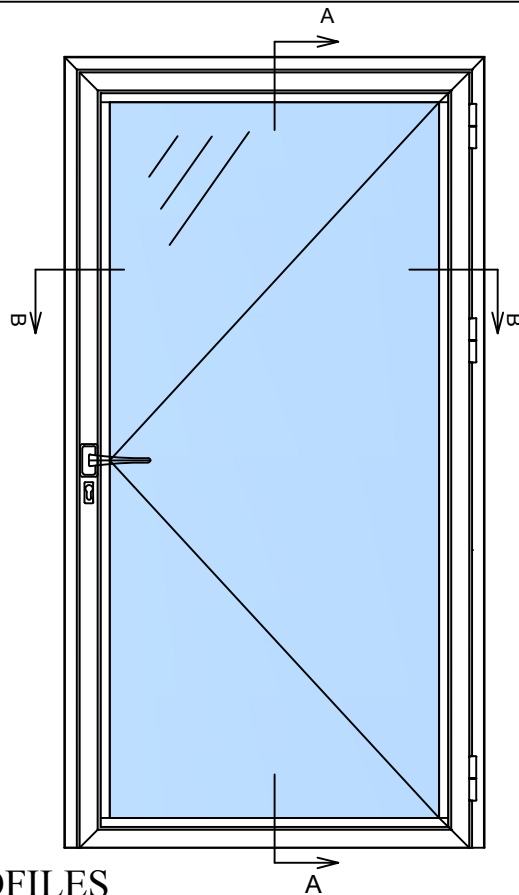

PROFILES

ACCESSOIRES

REF.	QTE	DESIGNATION	COUPE	DEBIT	REF.	QTE	DESIGNATION
500	1	DORMANT SANS C.J.	45°	L	E36-14	2	EQUERRE A PION
500	2	DORMANT SANS C.J.	45°-90°	H	E33.5-36	4	EQUERRE A PION
527	2	Z OUVRANT	45°	L-42	553F	3-4	PAUMELLES
527	2	Z OUVRANT	45°	H-27	554F	1	POIGNEE BEQUILLE
	2	PARCLOSE	90°	L-175.6	560	1	SERRURE COMPLET
	2	PARCLOSE	90°	H-200.4			
516	1	BAS DE PORTE	90°	L-42			
		COTES DE VITRAGE					
		L-160.6					
		H-175.6					
							JOINTS
					592	2L+2H	JOINT DE BATTUE
					594-595	2L+2H	JOINT DE VITRAGE
					593	2L+2H	JOINT FEUILLURE
					596	1L+2H	JOINT DORMANT
					591	2L+2H	JOINT FROID CENTRALE

COUPE A-A

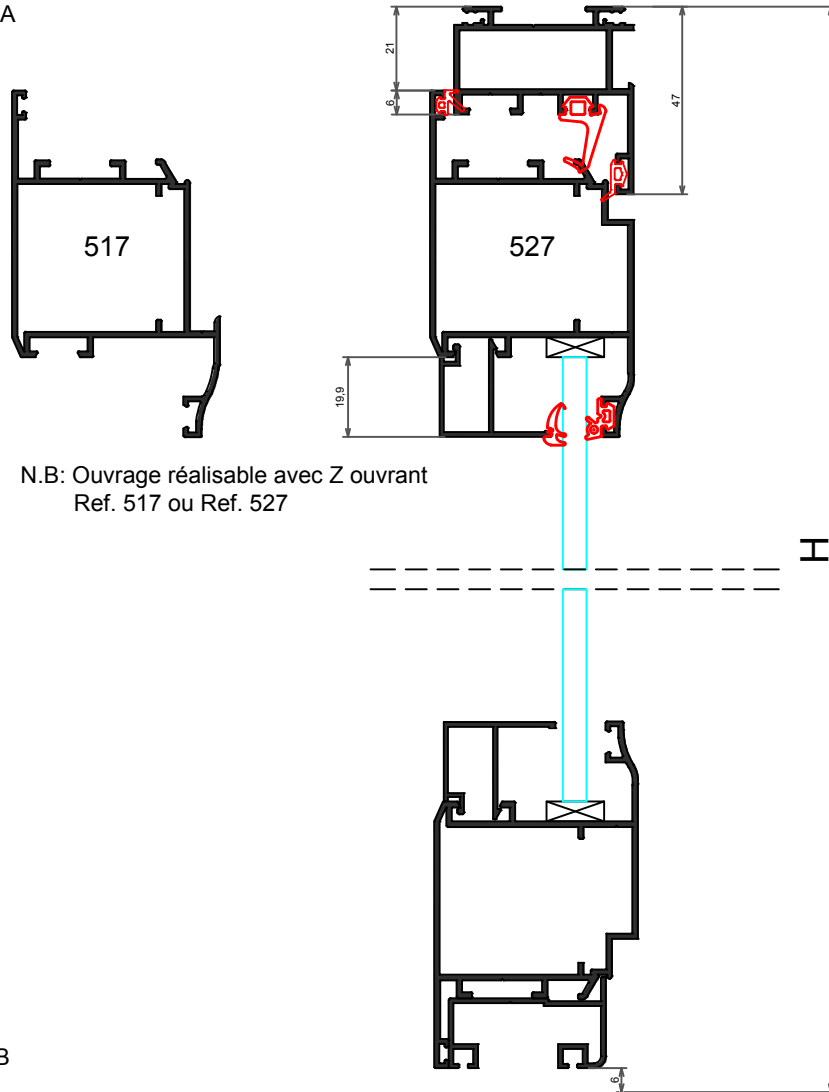

COUPE B-B

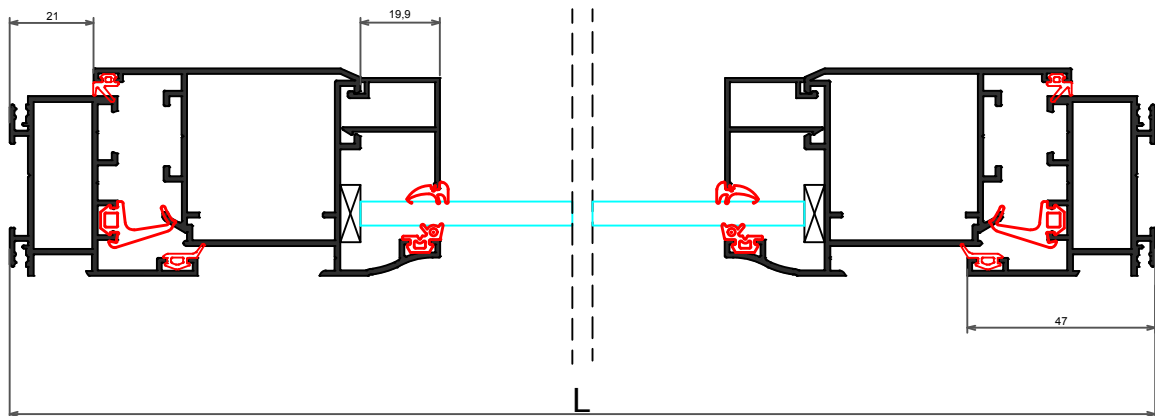

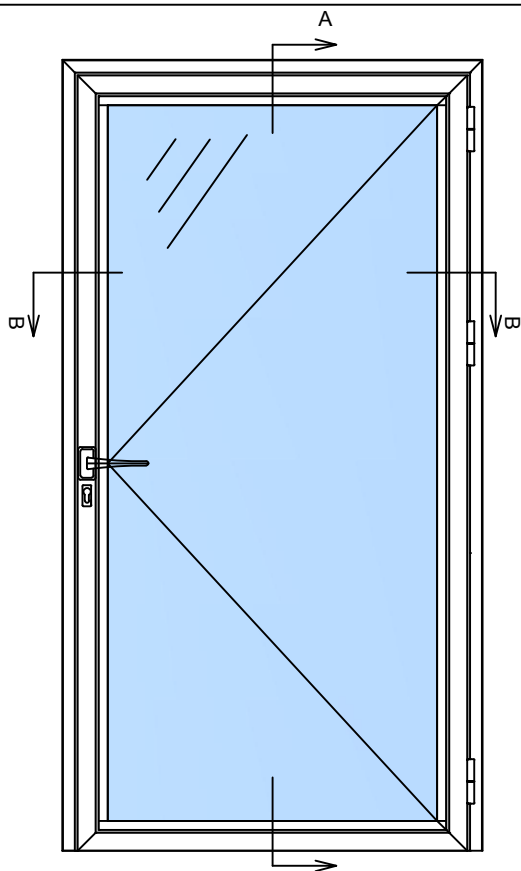

PROFILES

ACCESSOIRES

REF.	QTE	DESIGNATION	COUPE	DEBIT	REF.	QTE	DESIGNATION
501	1	DORMANT AVEC C.J.	45°	L+50	E36-14	2	EQUERRE A PION
501	2	DORMANT AVEC C.J.	45°-90°	H+50	E33.5-36	4	EQUERRE A PION
527	2	Z OUVRANT	45°	L-42	553F	3-4	PAUMELLES
527	2	Z OUVRANT	45°	H-27	554F	1	POIGNEE BEQUILLE
	2	PARCLOSE	90°	L-175.6	560	1	SERRURE COMPLET
	2	PARCLOSE	90°	H-200.4			
516	1	BAS DE PORTE	90°	L-42			
		COTES DE VITRAGE					
		L-160.6					
		H-175.6					
							JOINTS
					592	2L+2H	JOINT DE BATTUE
					594-595	2L+2H	JOINT DE VITRAGE
					593	2L+2H	JOINT FEUILLURE
					596	1L+2H	JOINT DORMANT
					591	2L+2H	JOINT FROID CENTRALE

COUPE A-A

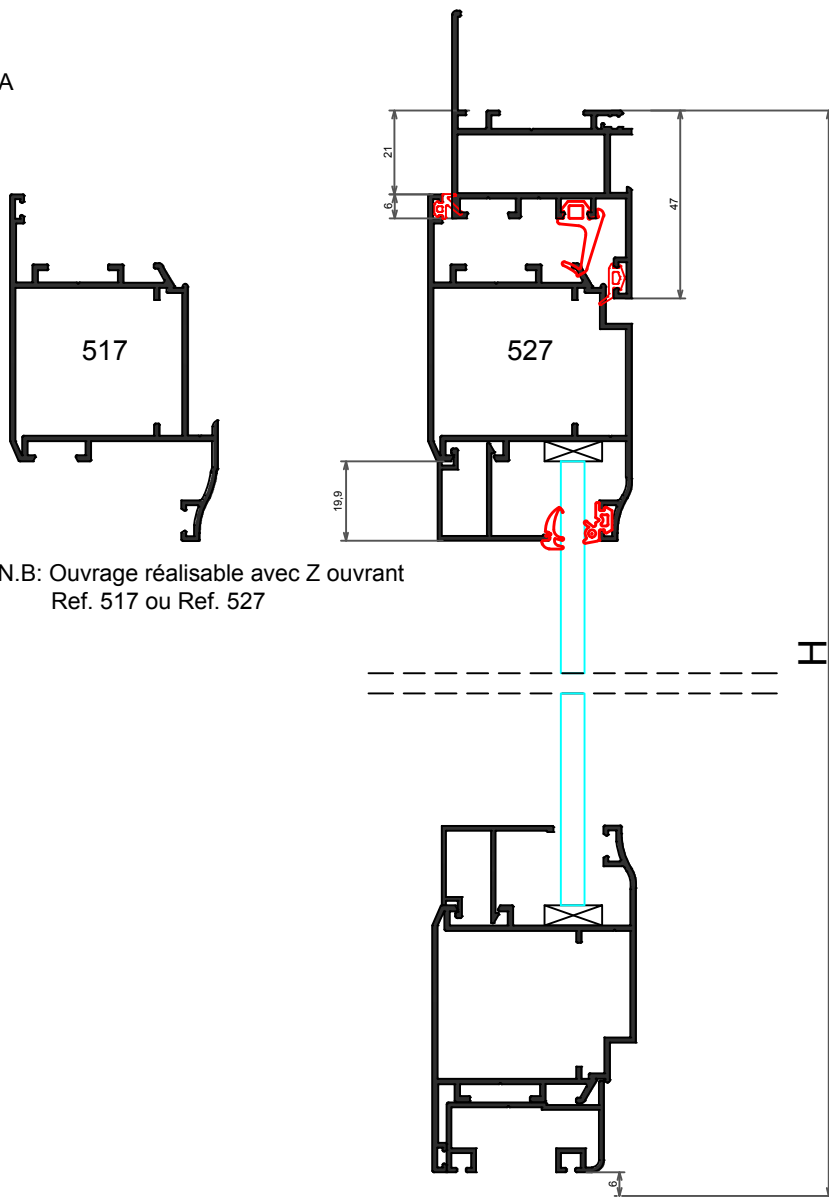

N.B: Ouvrage réalisable avec Z ouvrant
Ref. 517 ou Ref. 527

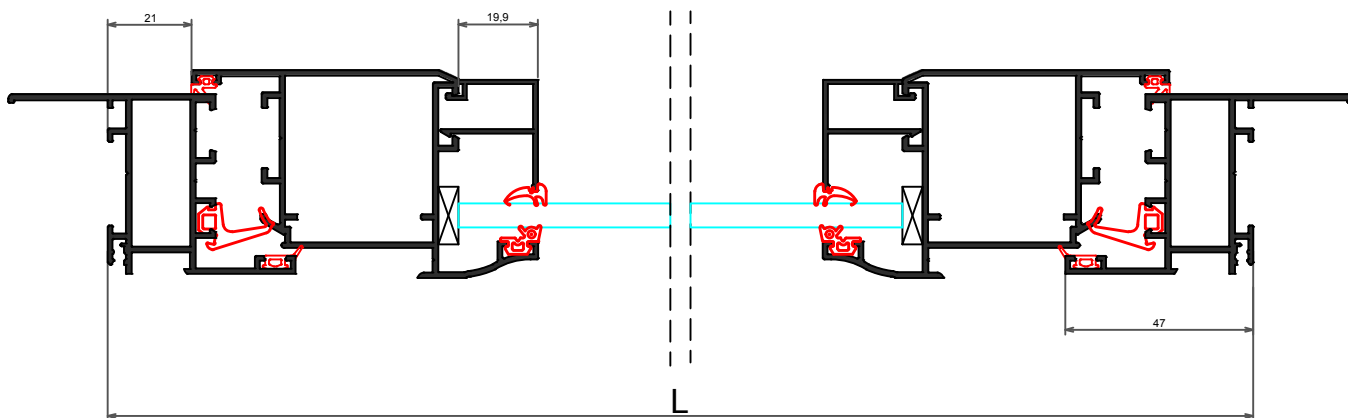

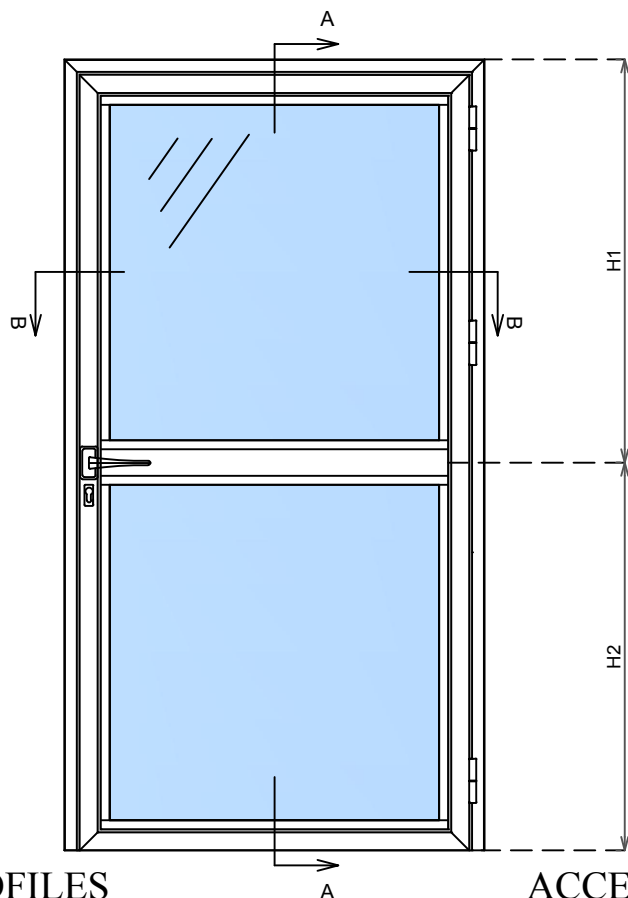

PROFILES
ACCESSOIRES

REF.	QTE	DESIGNATION	COUPE	DEBIT	REF.	QTE	DESIGNATION
500	1	DORMANT SANS C.J.	45°	L	E36-14	2	EQUERRE A PION
500	2	DORMANT SANS C.J.	45°-90°	H	E33.5-36	4	EQUERRE A PION
527	2	Z OUVRANT	45°	L-42	553F	3-4	PAUMELLES
527	2	Z OUVRANT	45°	H-27	554F	1	POIGNEE BEQUILLE
	4	PARCLOSE	90°	L-175.6	560	1	SERRURE COMPLET
	2	PARCLOSE	90°	H1-152.9	563	2	CAVALIERS TRAVERSES
	2	PARCLOSE	90°	H2-137.9			
506	1	TRAVERSE	90°	L-175.6			
516	1	BAS DE PORTE	90°	L-42			
		COTES DE VITRAGE					
		L-175.6			592	2L+2H	JOINT DE BATTUE
		H-118.1			594-595	2L+4H	JOINT DE VITRAGE
		H2-103.1			593	2L+4H	JOINT FEUILLURE
					596	1L+2H	JOINT DORMANT
					591	2L+1H	JOINT FROID CENTRALE
							JOINTS

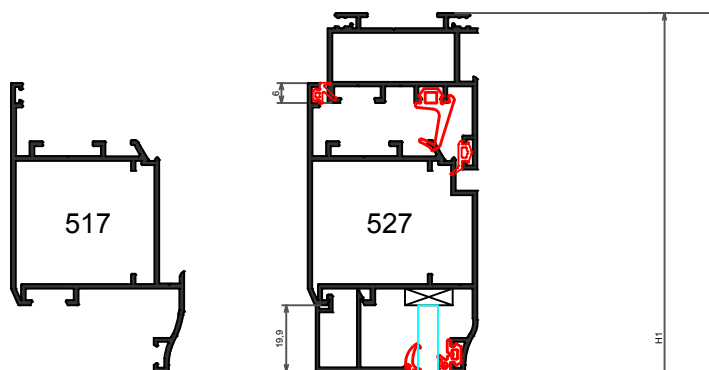
COUPE A-A

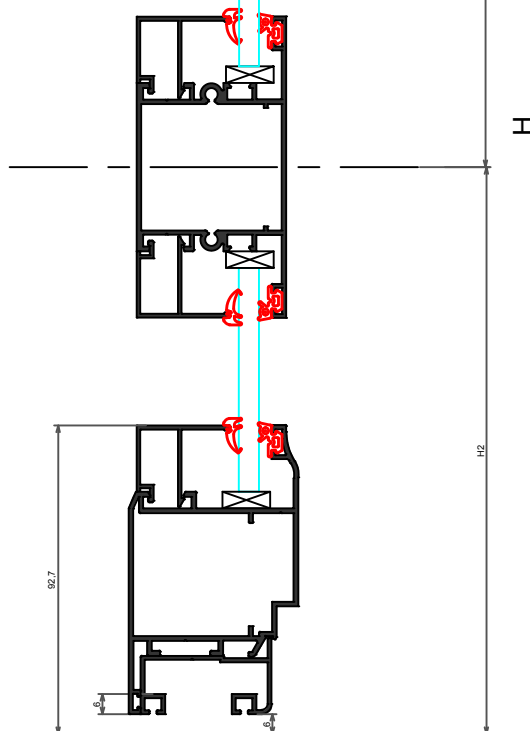

N.B: Ouvrage réalisable avec Z ouvrant
Ref. 517 ou Ref. 527



COUPE B-B

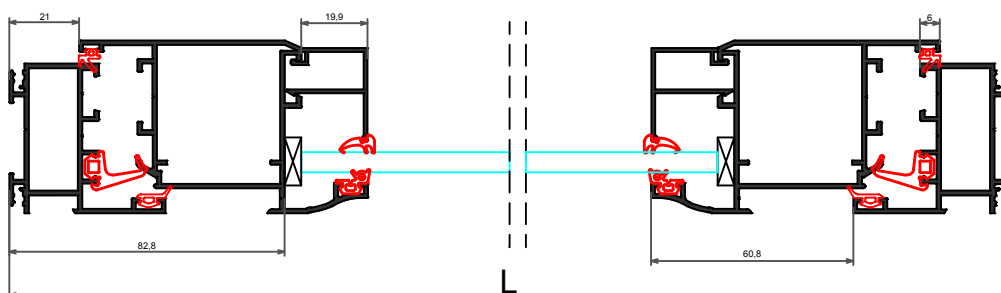

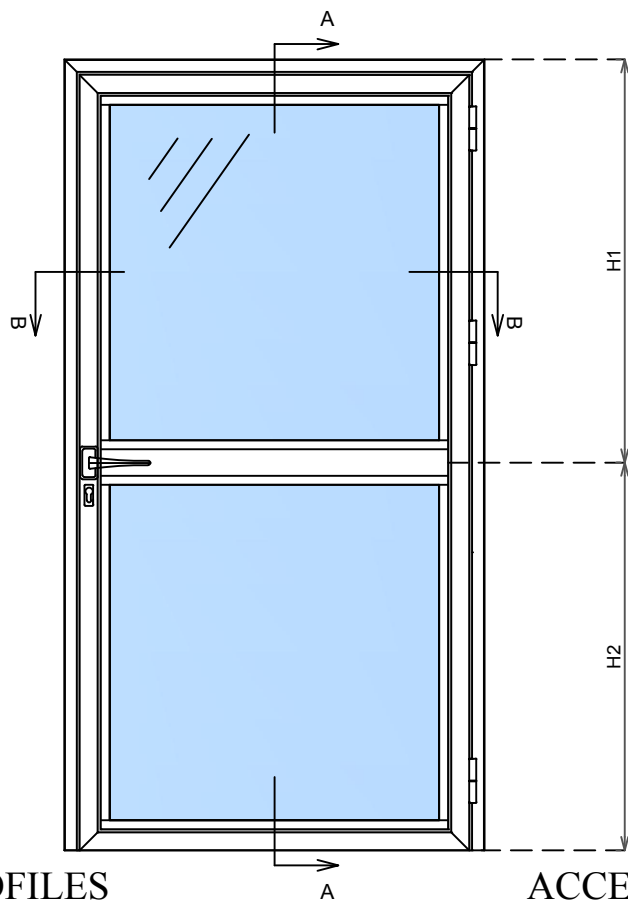
PROFILES
ACCESSOIRES

REF.	QTE	DESIGNATION	COUPE	DEBIT	REF.	QTE	DESIGNATION
501	1	DORMANT AVEC C.J.	45°	L+50	E36-14	2	EQUERRE A PION
501	2	DORMANT AVEC C.J.	45°-90°	H+50	E33.5-36	4	EQUERRE A PION
527	2	Z OUVRANT	45°	L-42	553F	3-4	PAUMELLES
527	2	Z OUVRANT	45°	H-27	554F	1	POIGNEE BEQUILLE
	4	PARCLOSE	90°	L-175.6	560	1	SERRURE COMPLET
	2	PARCLOSE	90°	H1-152.9	563	2	CAVALIERS TRAVERSES
	2	PARCLOSE	90°	H2-137.9			
506	1	TRAVERSE	90°	L-175.6			
516	1	BAS DE PORTE	90°	L-42			
		COTES DE VITRAGE					
		L-175.6					
		H-118.1					
		H2-103.1					
							JOINTS
					592	2L+2H	JOINT DE BATTUE
					594-595	2L+4H	JOINT DE VITRAGE
					593	2L+4H	JOINT FEUILLURE
					596	1L+2H	JOINT DORMANT
					591	2L+1H	JOINT FROID CENTRALE

COUPE A-A

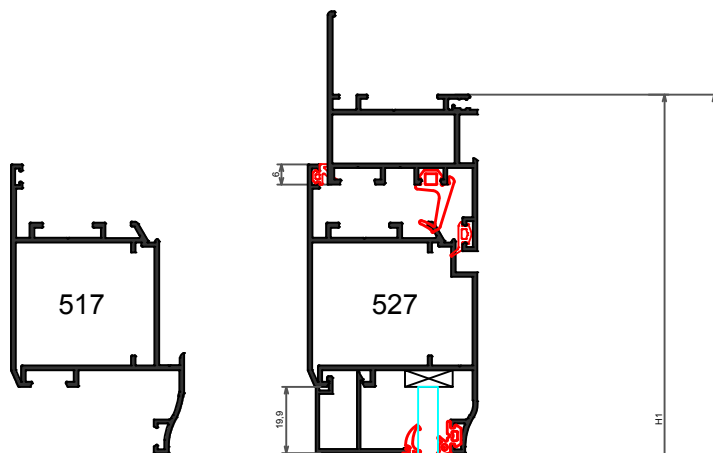

N.B: Ouvrage réalisable avec Z ouvrant
Ref. 517 ou Ref. 527

COUPE B-B

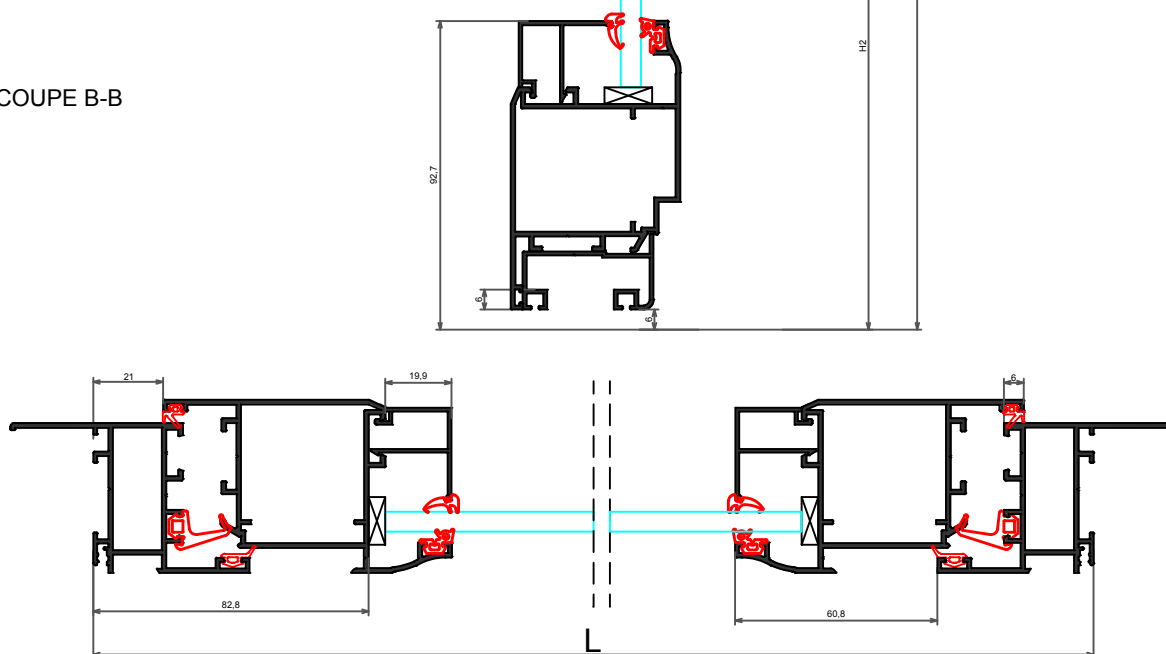

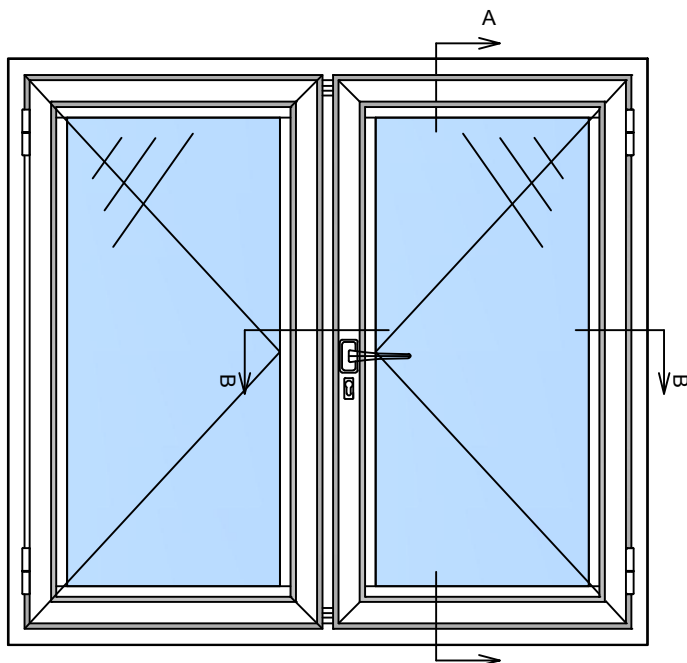

PROFILES

ACCESSOIRES

REF.	QTE	DESIGNATION	COUPE	DEBIT	REF.	QTE	DESIGNATION
500	2	DORMANT SANS C.J.	45°	L	E36-14	2	EQUERRE A PION
500	2	DORMANT SANS C.J.	45°	H	E33.5-36	8	EQUERRE A PION GRAND OUVRANT
503		TRINGLE OUVRANT	90°	H	553F	6-8	PAUMELLES
527	4	OUVRANT PORTE FENETRE	45°	L/2-13.2	561F/450	2	VERROU POUR SEMI-FIXE
527	3	OUVRANT PORTE FENETRE	45°	H-27	557/G	1	GACHE DOUBLE
519	1	INVERSEUR PORTE FENETRE	45°	H-27	554F	1	POIGNEE BEQUILLE
	4	PARCLOSE	90°	L/2-146.8	560	1	SERRURE 1 POINT COMPLET
	4	PARCLOSE	90°	H-200.4			
		COTES DE VITRAGE					
		H-160.6					
		L/2-146.8					
					592	2L+3H	JOINTS
					594-595	2L+4H	JOINT DE BATTUE
					593	2L+4H	JOINT DE VITRAGE
					596	1L+3H	JOINT FEUILLURE
					591	1L+3H	JOINT DORMANT
							JOINT FROID CENTRALE

COUPE A-A

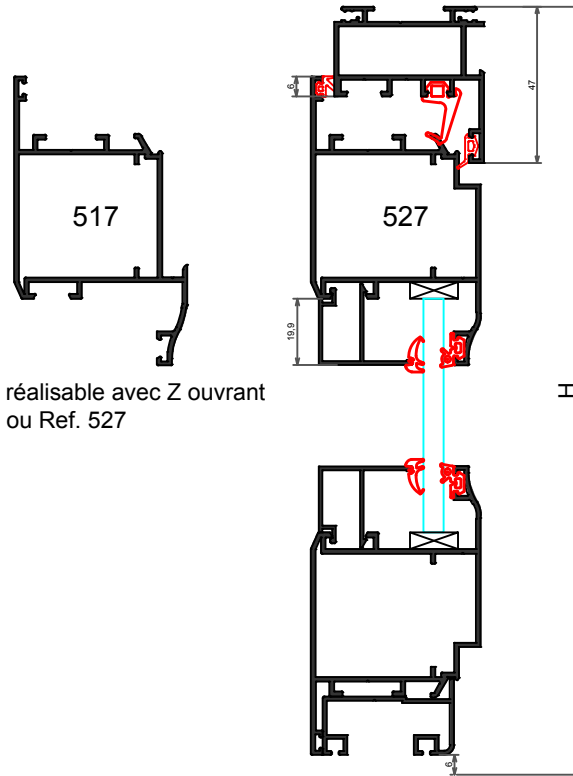

N.B: Ouvrage réalisable avec Z ouvrant
Ref. 517 ou Ref. 527

COUPE B-B

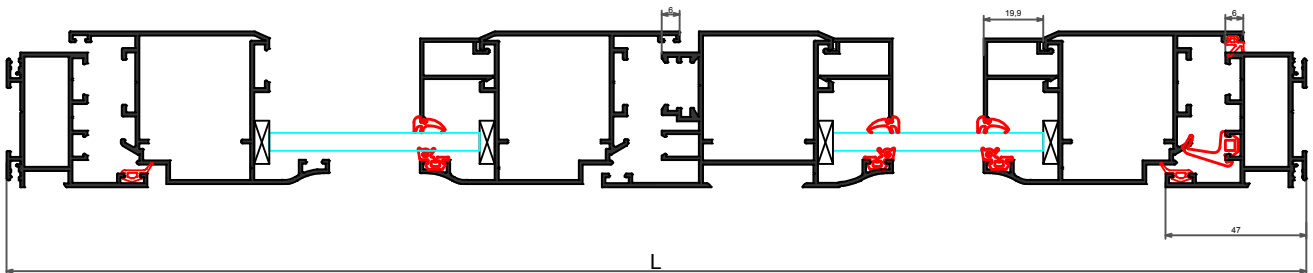

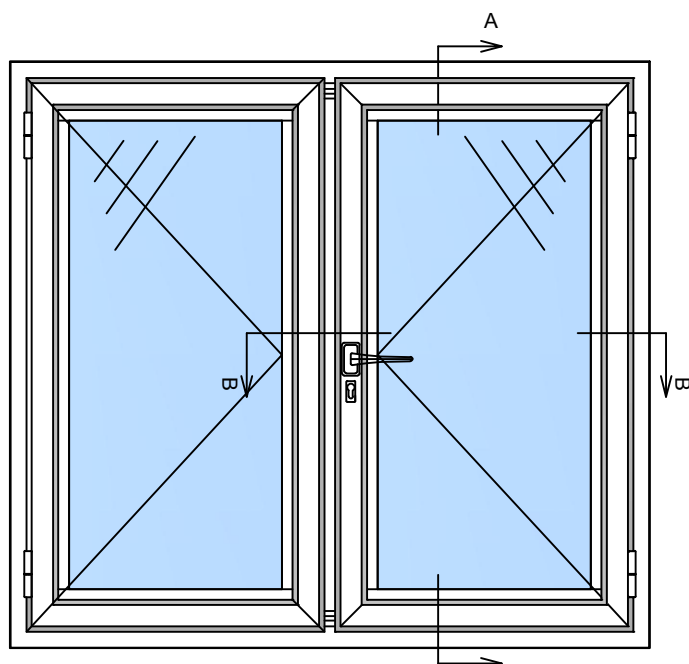
PROFILES
ACCESSOIRES

REF.	QTE	DESIGNATION	COUPE	DEBIT	REF.	QTE	DESIGNATION
501	2	DORMANT AVEC C.J.	45°	L+50	E36-14	2	EQUERRE A PION
501	2	DORMANT AVEC C.J.	45°	H+50	E33.5-36	8	EQUERRE A PION GRAND OUVRANT
503		TRINGLE OUVRANT	90°	H	553F	6-8	PAUMELLES
527	4	OUVRANT PORTE FENETRE	45°	L/2-13.2	561F/450	2	VERROU POUR SEMI-FIXE
527	3	OUVRANT PORTE FENETRE	45°	H-27	557/G	1	GACHE DOUBLE
519	1	INVERSEUR PORTE FENETRE	45°	H-27	554F	1	POIGNEE BEQUILLE
	4	PARCLOSE	90°	L/2-146.8	560	1	SERRURE 1 POINT COMPLET
	4	PARCLOSE	90°	H-200.4			
		COTES DE VITRAGE					
		H-160.6					
		L/2-146.8					
					592	2L+3H	JOINTS
					594-595	2L+4H	JOINT DE BATTUE
					593	2L+4H	JOINT DE VITRAGE
					596	1L+3H	JOINT FEUILLURE
					591	1L+3H	JOINT DORMANT
							JOINT FROID CENTRALE

COUPE A-A

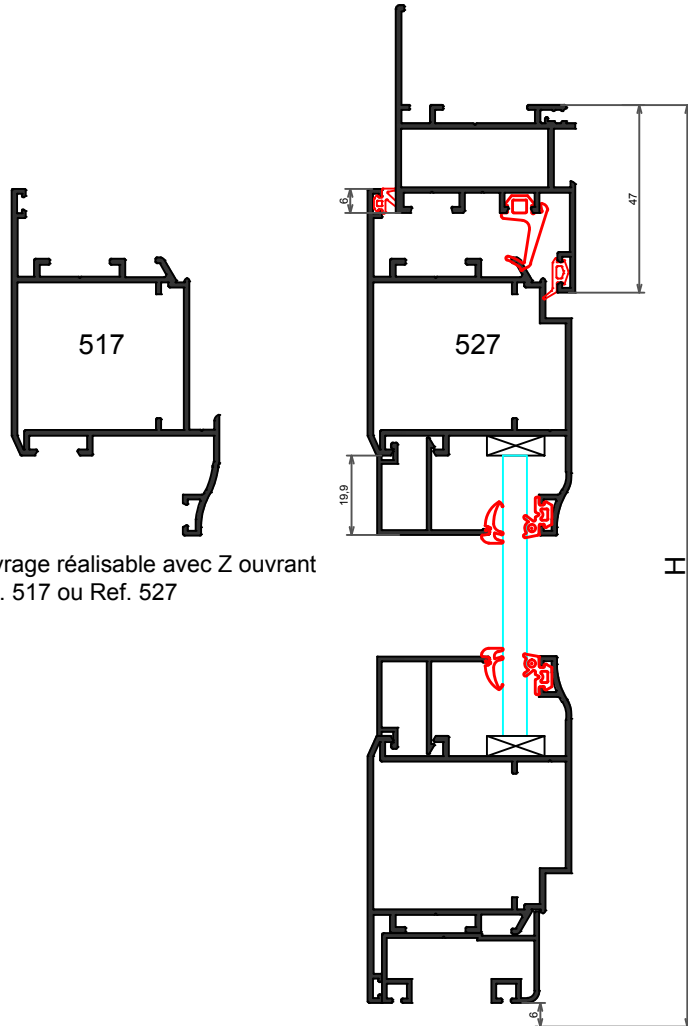

N.B: Ouvrage réalisable avec Z ouvrant
Ref. 517 ou Ref. 527

COUPE B-B

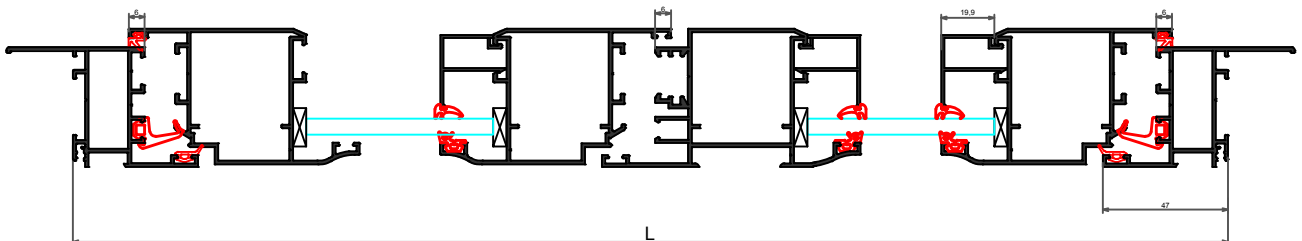

OUTILS ET DETAILS

ALU B2-ALUCA

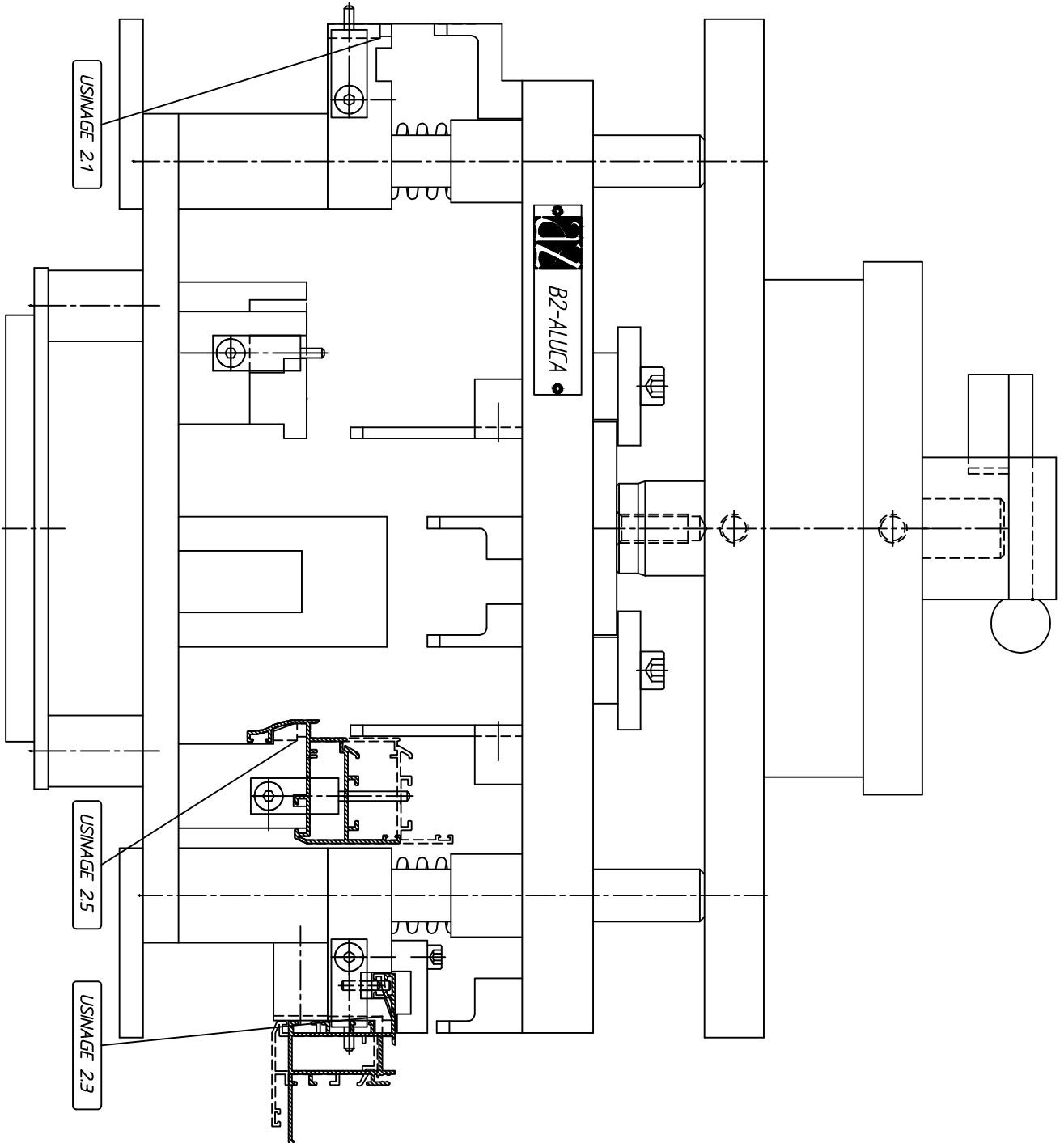

idz B2-ALUCA

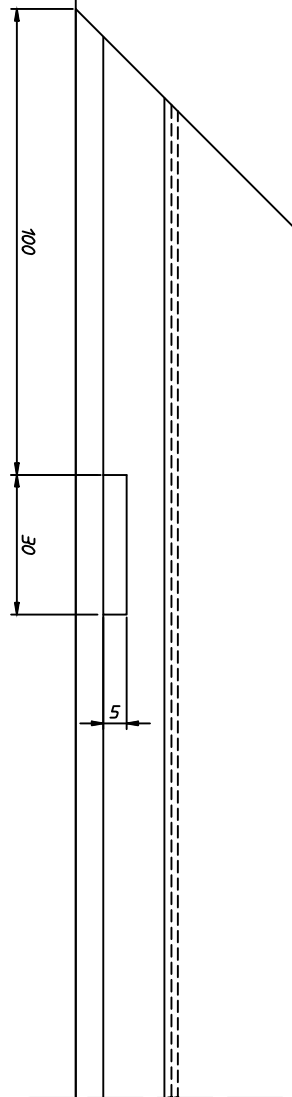
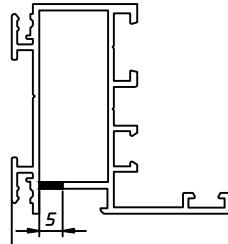
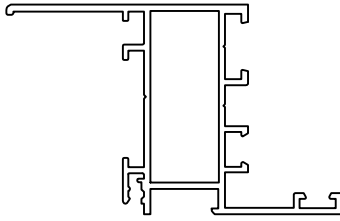

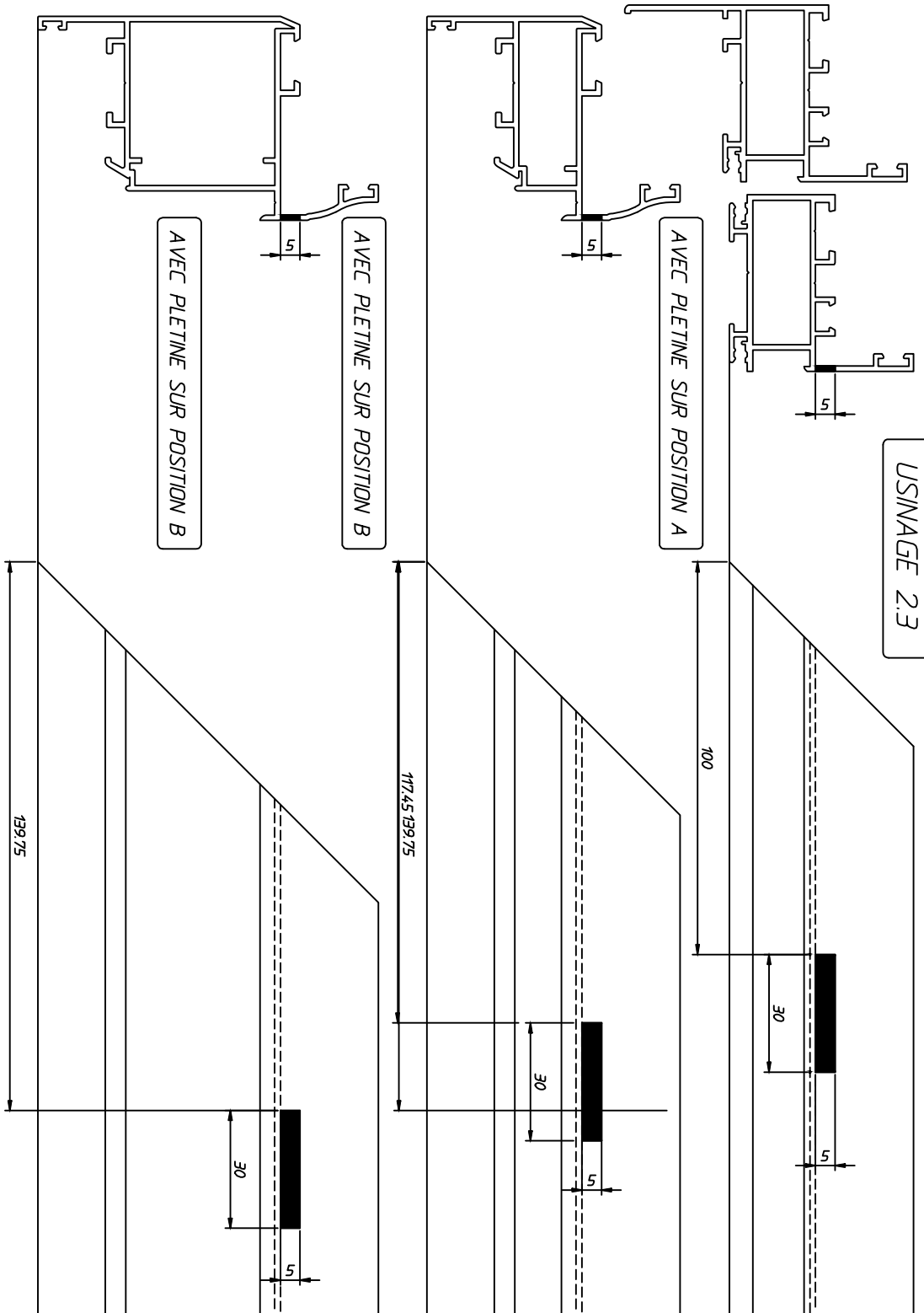

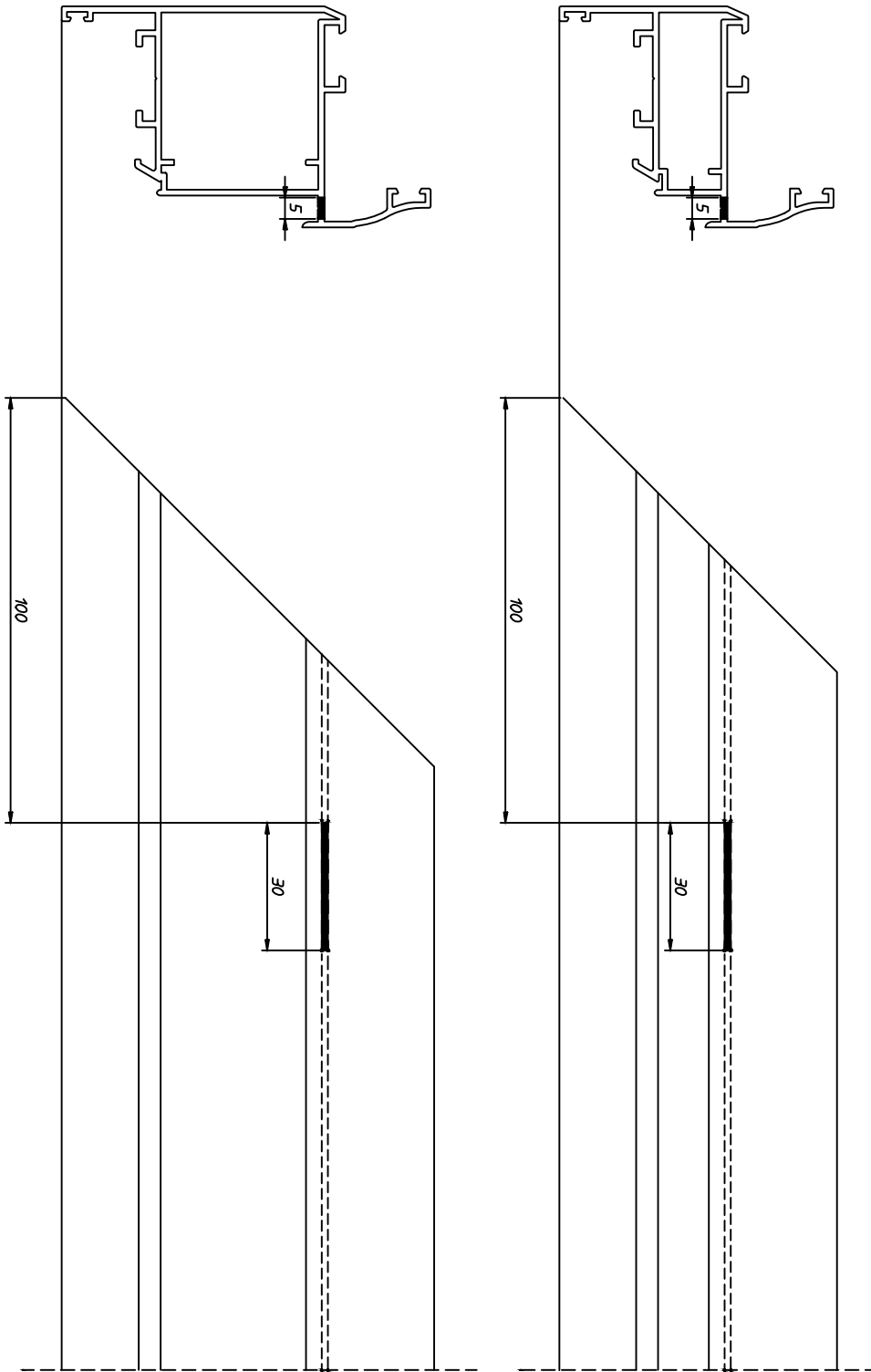

USNAGE 2.5

dz B2-ALUCA

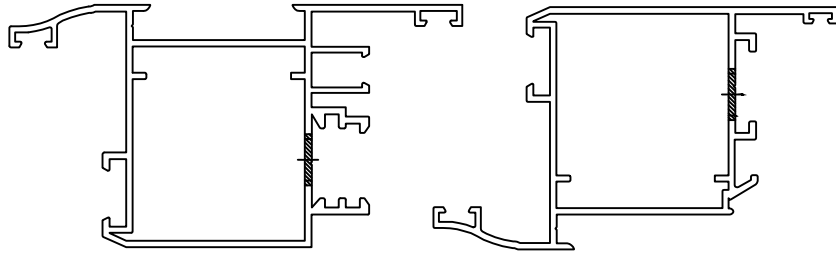

USINAGE 3.5

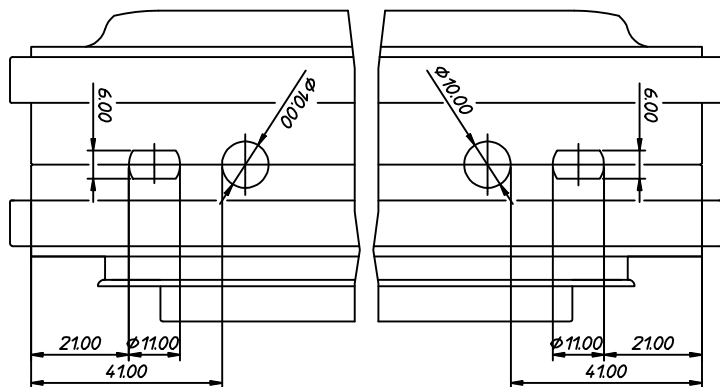
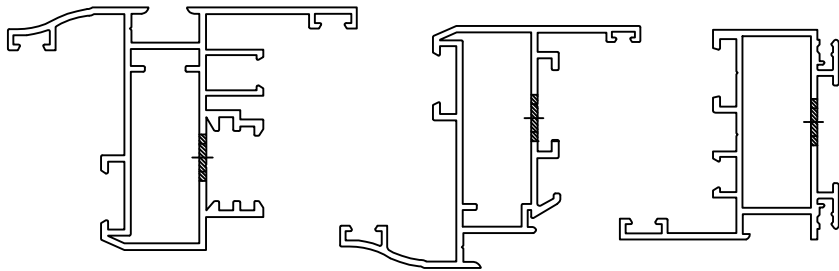
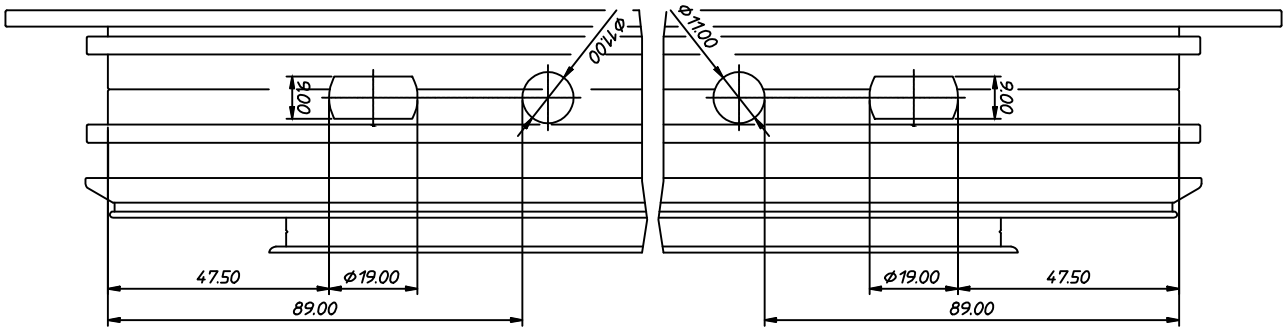

USINAGE 3.4

ALU B3-ALUCA

